

# PARTS BOOK

## KM-235A/B

고속 1본침 본봉 자동사절 재봉기

High Speed, 1-Needle, Lock Stitch Machine  
with Automatic Thread Trimmer



PME-110622

SunStar CO., LTD.



# INFORMATION

## A. Parts Book 구성 Structure of Part Book

① **A** Machine Body Mechanism  
두부 및 외장 관계

④ ⑤ ⑥ ⑦ ⑧ ⑨

No.	Parts No.	Note.	Name of Parts	품 명	Q'ty		Assembly No.
					BS	BP	
A-52	418055-306H		Bobbin Winder Lever	실감기 레버	1	1	
A-53	418018-306H		Bobbin Winder Adjusting Plate	실감기 조절판	1	1	
A-54	SC-0330-1230		Screw(LX <sup>®</sup> n=40)	볼트 (플라스틱)	1	1	
A-55	02-011W-2302		Washer	와셔	1	1	
A-56	418018-306H		Bobbin Winder Lever Shaft	실감기 레버 축	1	1	
A-57	418018-306H		Bobbin Winder Adjusting Cam	실감기 조절 캠	1	1	
A-58	0301205-4113		Screw(M4x16.2)	볼트	1	1	
A-59	94-090C-2710		E-Ring(#2)	토링(호칭링 2)	2	2	
A-60	418078-306H		Bobbin Winder Action Plate	실감기 작동판	1	1	
A-61	41-088A-120H		Bobbin Winder Action Body	실감기 작동체	1	1	
A-62	40-007W-1000		Washer	와셔	2	2	
A-63	418018-306H		Bobbin Winder Spring	실감기 인장 스프링	1	1	
A-64	418028-306H		Bobbin Stopper	보빈 스톱퍼	1	1	
A-65	418028-306H		Screw	볼트	5	5	
A-66	418048-306H		Bobbin Stand	보빈 스탠드	1	1	
A-67	418058-306H		Bobbin Winder Mes	실감기 메스	1	1	
A-68	SC-610-2302		Screw(LX <sup>®</sup> n=40)	고양베스 평리 코발트나사	2	2	
A-69	418078-306H		Thread Tension Adjusting Ax' y	실감기 실감력 조절장치(조)	1Set	1Set	
A-70	418028-306H		Thread Tension Adjusting Shaft	실감기 실감력 조절 축	1	1	
A-71	418028-306H		Thread Guide Plate	실감판 판	1	1	
A-72	40-204A-1230		Thread Tension Disk	실감판 원시	2	2	
A-73	40-330G-125A		Thread Tension Spring	실감력 조절 스프링	1	1	
A-74	40-80W-1230		Thread Tension Spring Stopper	실감력 조절 스프링 스톱퍼	1	1	
A-75	40-054A-1230		Spring Cover	스프링 커버	1	1	
A-76	40-204A-2250		Thread Tension Nut	실감력 조절 링 너트	1	1	
A-77	SN-0121-7400		Nut(1.5/16" n=20)	실감력 조절 축 너트	1	1	
A-78	018048-306H		Safety Plate Ax' y	안전판(조)	1Set	1Set	
A-79	018048-306H		Safety Plate	안전판	1	1	
A-80	018048-306H		Safety Plate Bracket	안전판 브라켓	1	1	
A-81	018048-306H		Safety Plate Holder	안전판 홀더	1	1	
A-82	018048-306H		Safety Plate Hinge Screw	안전판 힌지나사	1	1	
A-83	SN-0101-7400		Nut(1/16" n=20)	너트	3	3	
A-84	40-007W-1000		Washer	와셔	1	1	
A-85	018058-306H		Safety Plate Spring	안전판 스프링	1	1	
A-86	018015-306H		Safety Plate Spring Hook	안전판 스프링 걸이	1	1	
A-87	SN-0111-1000		Nut(1/16" n=20)	너트	1	1	
A-88	GP-01206-02		Ball Cover	보타커버	1	1	
A-89	SC-0407-1230		Screw(L1.5/16" n=40)	플라스틱 나사	7	7	
A-90	GP-01223-00		X-Driving Motor Cover	X 구동 모터 커버	1	1	
A-91	GP-01221-00		Side Cover	옆뚜껑	1	1	
A-92	GP-012215-00		Side Cover Gasket	옆뚜껑 가스켓	1	1	

- ① 관계 별 고유 코드  
Unique code by mechanism
- ② 관계 별 고유 명칭  
Unique name by mechanism
- ③ 관계도  
Explode view
- ④ Ref. No. : 파트별 고유 식별 번호  
Unique identification number by part
- ⑤ Parts No. : 고유 제품 코드  
Unique Product code

- ⑥ Note. : 공지사항 표기 및 메모  
Refers to notice and memo
- ⑦ 품명 : 파트의 고유 품명  
Name of Part : Unique name of parts
- ⑧ Q'ty : 파트의 수량  
The numer of parts
- ⑨ Assembly no. : 조(組) 파트의 식별 번호  
Unique identification number by set part

Ex)

구분 Category	Code	비고 Category
구 부품 Old part	01-030C-1230	
신 부품 New part	AS-000000-00	조(組)파트 Set parts
	GP-000000-00	기구적 파트 Instrumental parts
	EP-000000-00	전기적 파트 Electrical parts

# WARNING

1. 조에 속한 파트는 개별 조립 시 제품의 파손 또는 재봉 불량 발생될 수 있어 해당 파트에 대한 주문 시에는 조 품목으로만 구입이 가능합니다.
2. 본 책자는 Part Book으로 제작되었으므로 매뉴얼로 사용 불가합니다.
3. 사전 예고 없이 사양이 변경 될 수도 있습니다.

1. The parts classified as ass'y items may cause damage to the machine or bad sewing when they are separately assembled. Hence, when they are ordered, they can be purchased as ass'y items only.
2. This is a parts book. It cannot be used as a manual.
3. Parts are Subject to change in Design Without Prior Notice.

# CONTENTS

## 목 차

<b>A</b>	<i>Machine Body &amp; Thread Tension Adjusting Mechanism</i> 외장 및 실장력 조절 관계.....	4
<b>B</b>	<i>Upper Shaft, Needle Bar, Thread Take-Up, Synchronizer Mechanism</i> 상축/바늘대/실채기/싱크로 나이저 관계.....	8
<b>C</b>	<i>Upright Shaft &amp; Lower Shaft Mechanism</i> 세운축 및 하축 관계.....	10
<b>D</b>	<i>Feed Mechanism</i> 피이드 관계.....	12
<b>E</b>	<i>Press Bar &amp; Tension Release Mechanism</i> 누름대 및 실 늦추기 관계.....	18
<b>F</b>	<i>Thread Trimmer Mechanism</i> 사절 관계.....	22
<b>G</b>	<i>Reverse Button Mechanism</i> 역진 버튼 관계.....	26
<b>H</b>	<i>Thread Wiper Mechanism</i> 와이퍼 관계.....	27
<b>I</b>	<i>Lubrication</i> 급유 관계.....	28
<b>J</b>	<i>Accessories</i> 액세서리 관계.....	30
<b>K</b>	<i>Program Unit Box &amp; Automatic Presser Foot Lifter</i> 프로그램 유닛 박스 및 자동 무릎 올림 관계.....	34
	* INDEX .....	38

# A

## Machine Body & Thread Tension Adjusting Mechanism 외장 및 실장력 조절 관계

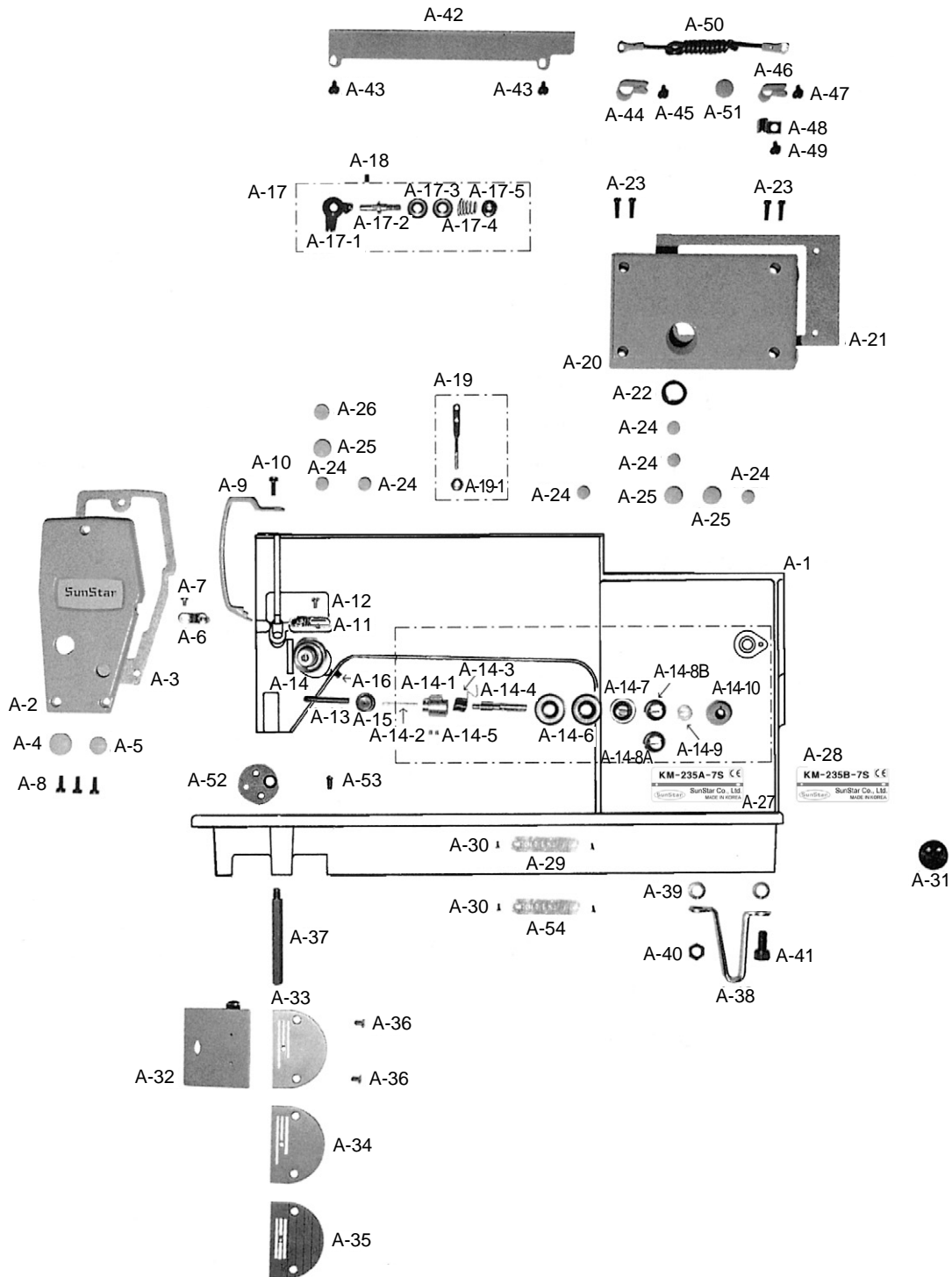

Ref. No.	Parts No.	Note	Name of Parts	품 명	Q' ty	Applied Period
A-1	AAB-SM008301		Arm, Bed Assembly	암,베드(조)	1Set	May.09.11
A-1-1	CAB-AA004600		Arm	암	1	
A-1-2	CAB-AB003908		Bed	베드	1	May.09.11
	CAB-AB003904		Bed	베드	1	Jan.12.11
A-1-3	DSC-AA003200		Screw	결합볼트(대)	2	
A-1-4	DSC-AA001300		Screw	암베드결합볼트B	1	
A-1-5	DSC-AZ000300		Screw	결합볼트	1	
A-2	CMB-LA018200		Face Plate	면판	1	
A-3	CMB-FC005900		Gasket	면판 패킹	1	
A-4	DPK-CB000900		Face Plate Rubber Cap(L)	면판 고무마개(대) 흰색(3-1)	1	
A-5	DPK-CB000200		Rubber Plug	면판 고무마개(중) 흰색(3)	1	
A-6	CMB-HK001900		Thread Guide Left	면판 실결이	1	
A-7	DSC-BA000100		Screw(9/64"n = 40)	오일펌프 커버 나사(9/64"n = 40)	1	
A-8	DSC-BJ000400		Screw(11/64"n = 40)	윗뚜껑 줌나사(11/64"n = 40)	3	
A-9	CMB-LA018000		Cover For Take Up Lever	실채기 커버	1	
A-10	DSC-BF003100		Screw(11/64"n = 40)	가마잡이 나사(11/64"n = 40)	1	
A-11	CMB-HK000500		Thread Guide For Arm	암 실결이	1	
A-12	DSC-BA000100		Screw(9/64"n = 40)	오일펌프 커버 나사(9/64"n = 40)	1	
A-13	DPN-AA014500		Tension Release Pin	실 늦추기 핀	1	
A-14	ATA-PS001303		Tension Adjusting Apparatus Ass'y	실 조절장치(사절용)	1Set	
A-14-1	CTA-BA000200		Tension Barrel	실 조절장치 붓싱	1	
A-14-2	DPN-AA003800		Tension Release Pin	사조자 핀	1	
A-14-3	DSP-BB000200		Check Spring	뽕뽕 스프링	1	
A-14-4	CTA-HM000500		Tension Stud	실 조절장치 축	1	
A-14-5	DSC-CA000200		Set Screw	실 조절장치 축 고정나사	2	
A-14-6	CTA-HL000100		Tension Disk	실 안내 접시	2	
A-14-7	CTA-BJ000100		Tension Release Washer	실 조절 스프링 받침	1	
A-14-8A	DSP-BA001000		Tension Spring	소라 스프링	1	
A-14-8B	DSP-BA002300		Tension Spring	소라 스프링	1	
A-14-9	DPK-CZ000200		Ratchet	실 조절장치 조절와셔	1	
A-14-10	DSN-CD000100		Cap	윗실 장력 조절 캡	1	
A-15	DPK-CZ000200		Packing	누유 방지용 캡	1	
A-16	DSC-CA000100		Screw(15/64"n = 28)	피드캠 고정나사(15/64"n = 28)	1	
A-17	ATA-PS001201		Supplementary Tension Ass'y	보조 실 조절장치(조)	1Set	
A-17-1	CTA-HK000200		Guide Plate	윗실 안내판	1	
A-17-2	CTA-HM000601		Shaft	보조 실 조절장치 축	1	
A-17-3	CTA-HL000300		Tension Disk	보조 실 조절 접시	2	
A-17-4	DSP-BA000900		Spring	보조 소라 스프링	1	

**NOTE:**

A=KM-235A  
B=KM-235B

# A

## Machine Body & Thread Tension Adjusting Mechanism 외장 및 실장력 조절 관계

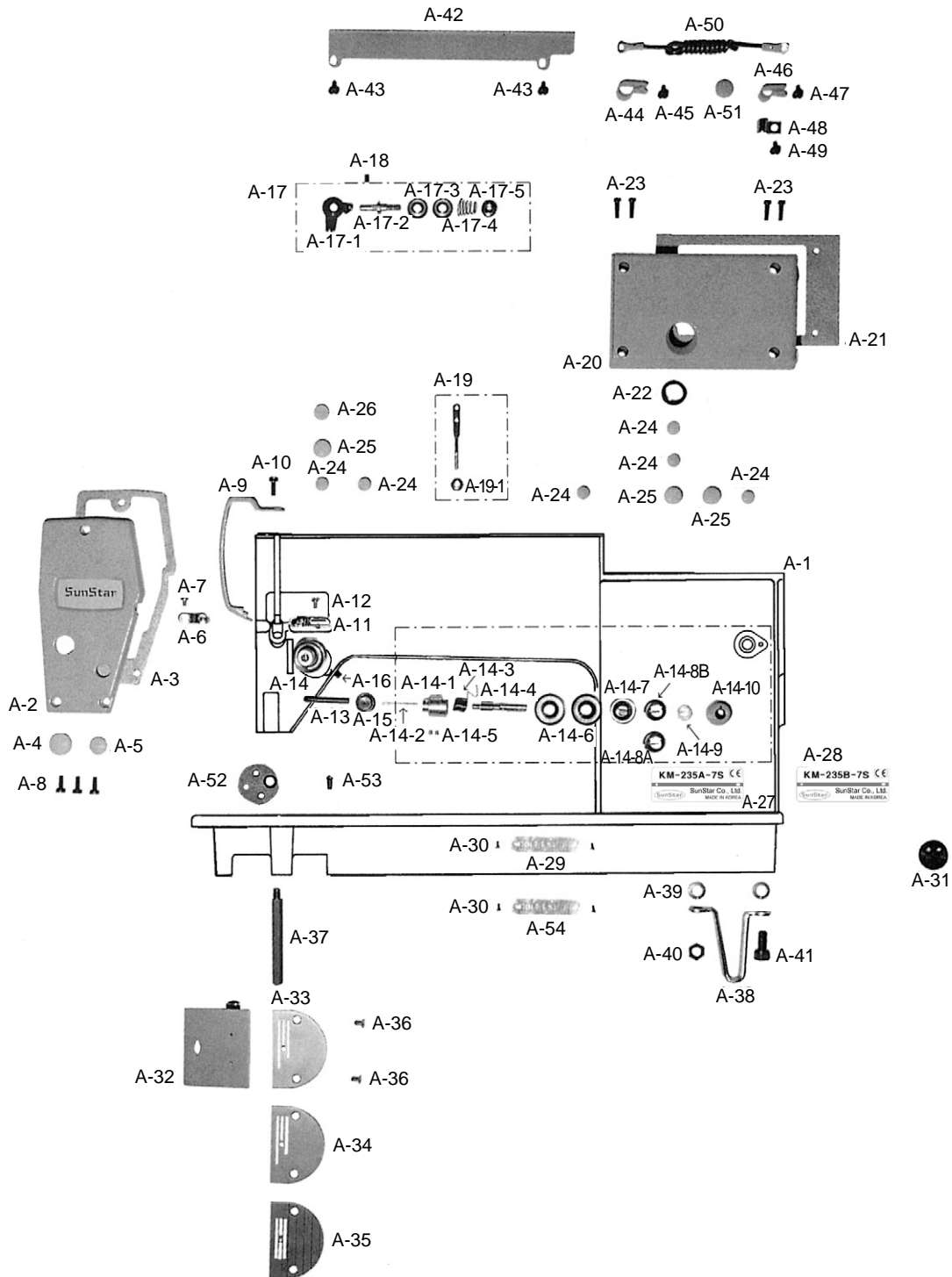



Ref. No.	Parts No.	Note	Name of Parts	품 명	Q' ty	Applied Period
A-17-5	DSN-CD000400		Nut	보조 실 조절장치 조절 너트	1	
A-18	DSC-CB000300		Screw(11/64"n=40)	하측 베어링 B/S 고정나사(11/64"n=40)	1	
A-19	CMB-HK002000		Guide Bar For Thread	실 안내봉	1	
A-19-1	DSN-AA000100		Nut	세구멍 실걸이 너트	1	
A-20	CMB-LA018100		Top Cover	윗 뚜껑	1	
A-21	CMB-FC005800		Gasket	윗 뚜껑 패킹	1	
A-22	CLB-JJ001200		Oil Gauge Window	유창	1	
A-23	DSC-BJ005900		Screw For Top Cover	톱커버 나사(신)	4	
A-24	DPK-CB002900		Robber Plug(Small)	고무마개(소) 회색(5)	6	
A-25	DPK-CB000200		Robber Plug(Large)	면판 고무마개(중) 회색(3)	3	
A-26	DPK-CA000100		Robber Plug	실 늦추기 힌지핀 고무마개	1	
A-27	CMB-LD003200	A	Model Mark	모델마크	1	
A-28	CMB-LD003500	B	Model Mark	모델마크	1	
A-29	01-035P-1230		Machine Number Plate	번호판	1	
A-30	PPN-AD000100		Setting Pin	번호판 핀	4	
A-31	DPK-CC001000		Rubber Plug For Cable	슬레노이드 케이블 안내 고무	1	
A-32	AMB-PS001400		Slide Plate Ass'y	미끄럼판(조)	1Set	
A-33	CGA-GA000200	A	Needle Plate	침판	1	
A-34	CGA-GA002000	B	Needle Plate	침판	1	
A-35	CGA-GA003200		Needle Plate (AL-Type)	침판(박물용)	1	
A-36	DSC-BC000100		Screw(11/64"n=40)	홈볼이 접시 작은나사(11/64"n=40)	2	
A-37	DSC-HC000300		Bed Leg Front	베드 받침(전)	1	
A-38	CMB-BB004500		Bed Leg Right	베드 받침	1	
A-39	PWS-CA000400		Spring Washer	베드 받침 스프링 와셔	2	
A-40	PSN-AA000500		Nut(M8×1.25)	베드 받침 너트(M8×1.25)	1	
A-41	PSC-AC002600		Screw(M8×1.25)	베드 받침 후 결합 볼트(M8×1.25)	1	
A-42	CMB-LB008000		Cable Cover	케이블 커버	1	
A-43	DSC-BJ003500		Screw(11/64"n=40)	슬레노이드 부착 고정나사(11/64"n=40)	2	
A-44	PTC-AH000100		Cable Holder(5N)	케이블 잡이C(5N)	1	
A-45	DSC-BA000900		Screw(9/64"n=40)	면판 측면 커버 나사(하)(9/64"n=40)	1	
A-46	PTC-AH000300		Cable Holder(6N)	케이블 잡이(6N)	1	
A-47	DSC-BA000900		Screw(9/64"n=40)	면판 측면 커버 나사(하)	1	
A-48	DTC-AH000100		Cable Holder	케이블 잡이	1	
A-49	DSC-BA000900		Screw(9/64"n=40)	면판 측면 커버 나사(하)(9/64"n=40)	1	
A-50	12-016M-2350		Earth Line	어스선(조)	1	
A-51	DPK-CB000200		Rubber Plug	면판 고무마개(중) 흰색(3)	1	
A-52	CMB-BJ002400		Gauge Plate	게이지 부착판	1	
A-53	DSC-BC000100		Screw for Needle Plate	침나사	1	
A-54	GP-048566-00		Mark	원산지 마크	1	

**NOTE:**

A=KM-235A  
B=KM-235B

# B

## Upper Shaft, Needle Bar, Thread Take-Up, Synchronizer Mechanism

상축/바늘대/실채기/싱크로나이저 관계

B-45

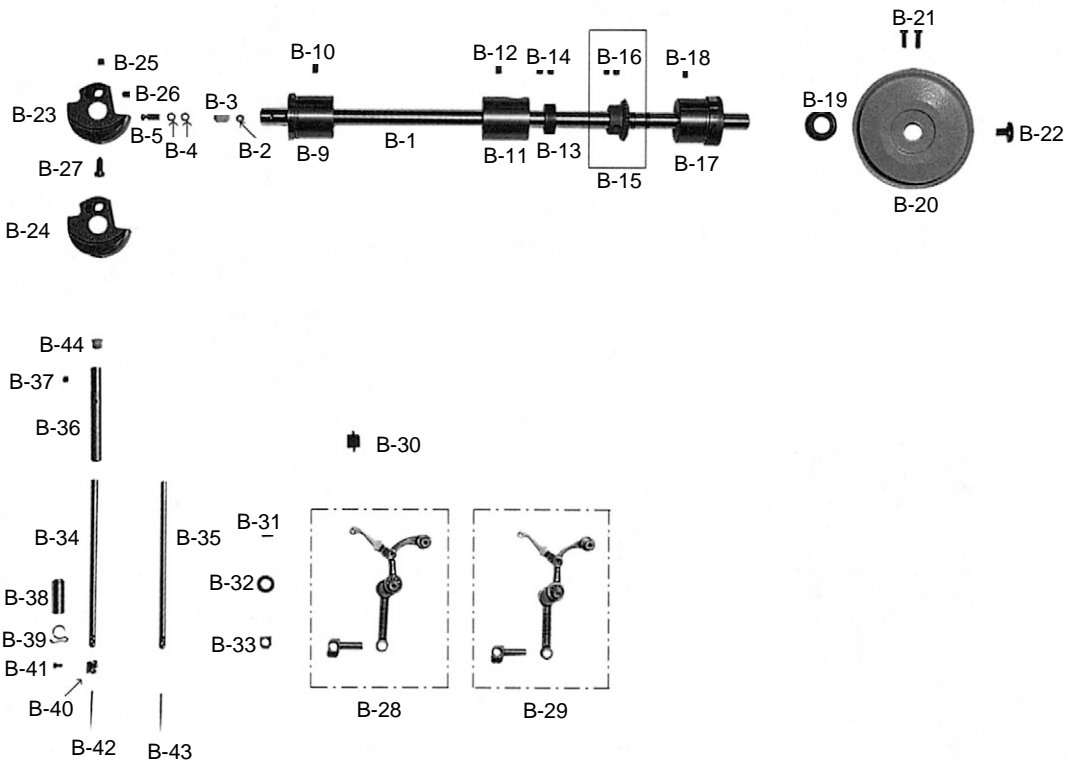
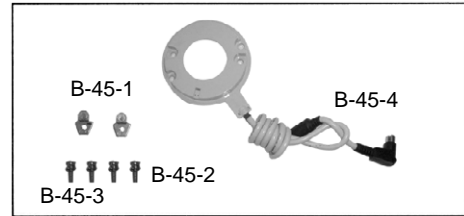

Ref. No.	Parts No.	Note	Name of Parts	품명	Q'ty	Applied Period
B-1	CUS-KC002601		Main Shaft	상축	1	
B-2	CUS-FA000100		Rubber	상축 유량 조절 고무	1	
B-3	CLB-JL001600		Felt	상축 felt	1	
B-4	PPK-BA000400		O-Ring	상축 유량 조절된 오링	2	
B-5	CUS-CH000101		Adjusting Valve For Lubrication	상축 유량 조절핀	1	
B-9	DBS-DB007600		Main Shaft Front Bushing	상축 앞 붓싱	1	
B-10	DSC-CA000800		Screw(15/64" n = 28)	상축 B/S 고정나사(15/64" n = 28)	1	
B-11	DBS-DA025800		Main Shaft Center Bushing	상축 중 붓싱	1	
B-12	DSC-CA000800		Screw(15/64" n = 28)	상축 B/S 고정나사(15/64" n = 28)	1	
B-13	DCL-AA000100		Main Shaft Collar	상축 카라	1	
B-14	DSC-CA000500		Screw(1/4" n = 40)	홈볼이 멈춤나사(1/4" n = 40)	2	
B-15	DGR-AD000100		Main Shaft Gear	상축 기어(국산)	1	
B-16	DSC-CA000500		Screw(1/4" n = 40)	홈볼이 멈춤나사(1/4" n = 40)	2	
B-17	DBS-DB001101		Main Shaft Rear Bushing	상축 뒷 붓싱	1	
B-18	DSC-CA000100		Screw(15/64" n = 28)	피드캠 고정나사(15/64" n = 28)	1	
B-19	PPK-AA000100		Oil Seal	상축 오일 씬	1	
B-20	DPL-AA000201		Pulley	풀리	1	
B-21	DSC-BF000800		Screw(15/64" n = 40)	풀리 고정나사(15/64" n = 40)	2	
B-22	DSC-BG000200		Screw(5/16" n = 28)	풀리 고정나사(5/16" n = 28)	1	
B-23	CUS-DA002600	A	Counterweight	링크캠(235A)	1	
B-24	CUS-DA002700	B	Counterweight	링크캠(235B)	1	
B-25	DSC-CA000500		Screw(1/4" n = 40)	홈볼이 멈춤나사(1/4" n = 40)	1	
B-26	DSC-CA001100		Screw(1/4" n = 40)	실체기 핀 고정나사(1/4" n = 40)	1	
B-27	DSC-BF003700		Screw(9/32" n = 28)	링크캠 위치 고정나사(9/32" n = 28)	1	
B-28	AS-016316-01	A	Take-Up Lever Complete	실체기(235A)	1	
B-29	AS-016315-01	B	Take-Up Lever Complete	실체기(235B)	1	
B-30	DPK-CZ000900		Oil Protection Rubber	실체기 기름막이 고무	1	
B-31	DSC-CA000800		Screw(15/64" n = 28)	상축 B/S 고정나사(15/64" n = 28)	1	
B-32	DWS-AA002700		Thrust Washer	링크캠 와셔	1	
B-33	CNB-CD000201		Sliding Block	바늘대 안내 블록(235A)	1	
B-34	CNB-KA002600	A	Needle Bar	바늘대	1	
B-35	CNB-KA002700	B	Needle Bar	바늘대	1	
B-36	DBS-DA003400		Needle Bar Upper Bushing	바늘대 상 붓싱	1	
B-37	DSC-CA001700		Screw(15/64" n = 28)	바늘대 B/S 나사	1	
B-38	DBS-DA024900		Needle Bar Lower Bushing	바늘대 하 붓싱	1	
B-39	CNB-HK002200		Thread Guide "A"	바늘대 붓싱 실결이	1	
B-40	CNB-HK002100		Thread Guide	바늘대 실결이(235A, B)	1	
B-41	DSC-BF000100		Screw(1/8" n = 44)	홈볼이 납작 작은나사(1/8" n = 44)	1	
B-42	-	A	Needle	바늘	1	
B-43	-	B	Needle	바늘	1	
B-44	DPK-CB000400		Rubber Cap	바늘대 상 붓싱 마개	1	
B-45	13-2000-SE55		Synchronizer Ass'y	싱크로나이저	1Set	
B-45-1	11-020A-2500		Magnetic Holder	마그네트 홀더	2	
B-45-2	11-022W-2500		Washer For Magnetic Holder	마그네트 홀더 와셔	4	
B-45-3	11-021S-2500		Screw For Magnetic Holder	마그네트 홀더 썸나사	4	
B-45-4	13-0000-SE55		Synchronizer Ass'y (Servo)	싱크로나이저(조)Servo	1	

**NOTE:**

A=KM-235A  
B=KM-235B



# Upright Shaft & Lower Shaft Mechanism

## 세운축 및 하축 관계

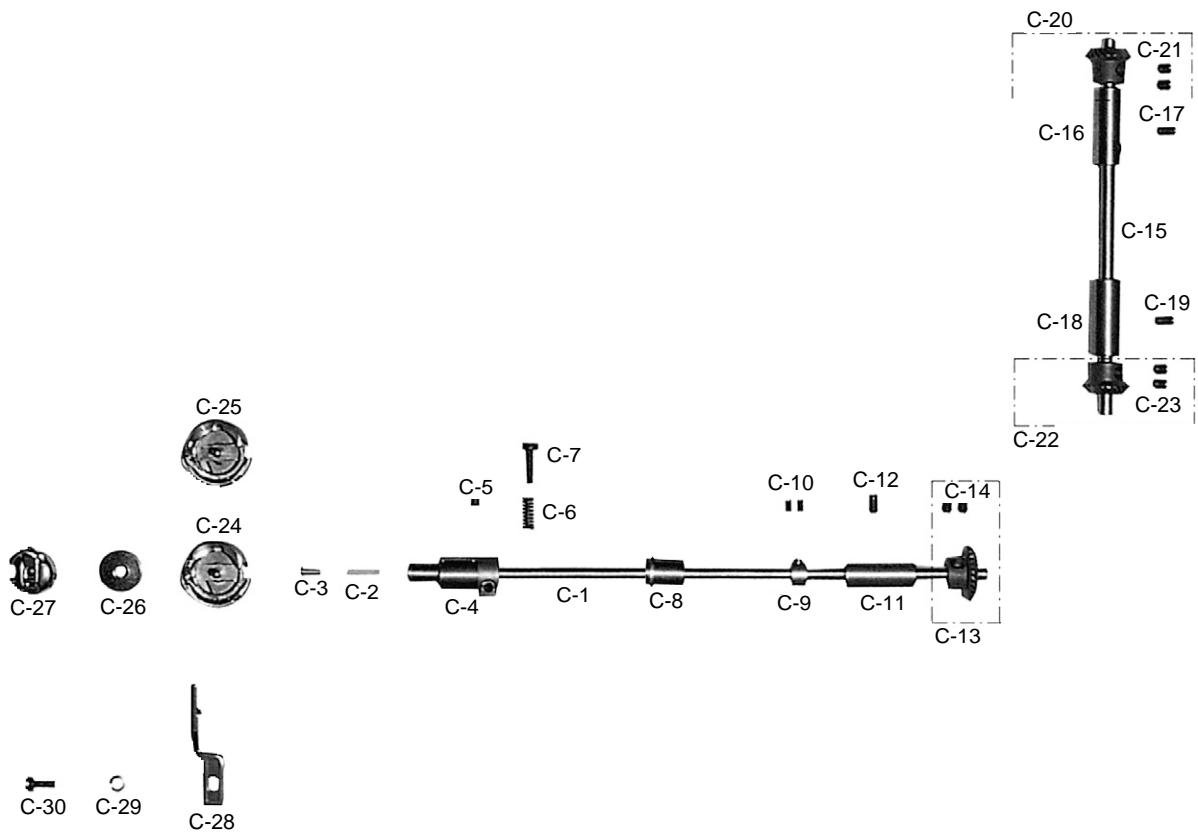

Ref. No.	Parts No.	Note	Name of Parts	품명	Q'ty	Applied Period
C-1	CLS-KC002600		Lower Shaft	하축(235A, B)	1	
C-2	CLB-JL002400		Felt	하축 펠트	1	
C-3	DSC-BF007000		Set Screw	하축 펠트 꽃이 나사	1	
C-4	DBS-DA025900		Lower Shaft Bushing(Front)	하축 앞 붓싱(235A, B)	1	
C-5	DSC-CA000100		Screw(15/34"n=28)	피드 캠 고정나사(15/64"n=28)	1	
C-6	DSP-AA001600		Spring	하축 오일 조절나사 스프링	1	
C-7	DSC-BF004000		Screw(3/16"n=32)	하축 오일 조절나사(3/16"n=32)	1	
C-8	DBS-DB007700		Lower Shaft Bushing(Center)	하축 중 붓싱	1	
C-9	DCL-AA001500		Collar(B)	오일 펌프 카라(B)	1	
C-10	DSC-CB000300		Screw(11/64"n=40)	하축 중 베어링 붓싱나사 (11/64"n=40)	2	
C-11	DBS-DA004100		Lower Shaft Rear Bushing	하축 뒷 붓싱	1	
C-12	DSC-CA000800		Screw(15/64"n=28)	상축 B/S 고정나사	1	
C-13	DGR-AD000400		Lower Shaft Gear	하축 뒷 기어	1	
C-14	DSC-CA000500		Screw(1/4"n=40)	홈볼이 멈춤나사(1/4"n=40)	2	
C-15	CUR-KC000100		Upright Shaft	입축	1	
C-16	DBS-DA003700		Vertical Shaft Upper Bushing	입축 상 붓싱	1	
C-17	DSC-CA000800		Screw(15/64"n=28)	상축 B/S 고정나사(15/64"n=28)	1	
C-18	DBS-DA003801		Upright Shaft Lower Bushing	입축 하 붓싱	1	
C-19	DSC-CA000800		Screw(15/64"n=28)	상축 B/S 고정나사(15/64"n=28)	1	
C-20	DGR-AD000200		Upright Shaft Upper Gear	입축 상 기어	1	
C-21	DSC-CA001900		Screw(1/4"n=40)	기어나사(1/4"n=40)	2	
C-22	DGR-AD000300		Upright Shaft Lower Gear	입축 하 기어	1	
C-23	DSC-CA001900		Screw(1/4"n=40)	기어나사(1/4"n=40)	2	
C-24	CHK-HA000700	A	Rotary Hook Ass'y	가마	1	
C-25	CHK-HA000900	B	Rotary Hook Ass'y	가마	1	
C-26	CHK-HB000600		Bobbin (A1)	보빈	1	
C-27	CHK-HC000700		Bobbin Case Ass'y	보빈 케이스	1	
C-28	CHK-HH000400		Hook Retainer	가마잡이	1	
C-29	DWS-CA000100		Spring Washer	가마잡이 와셔	1	
C-30	DSC-BF003100		Screw(11/64"n=40)	가마잡이 나사(11/64"n=40)	1	

**NOTE:**

A=KM-235A  
B=KM-235B

# D

## Feed Mechanism 피이드 관계

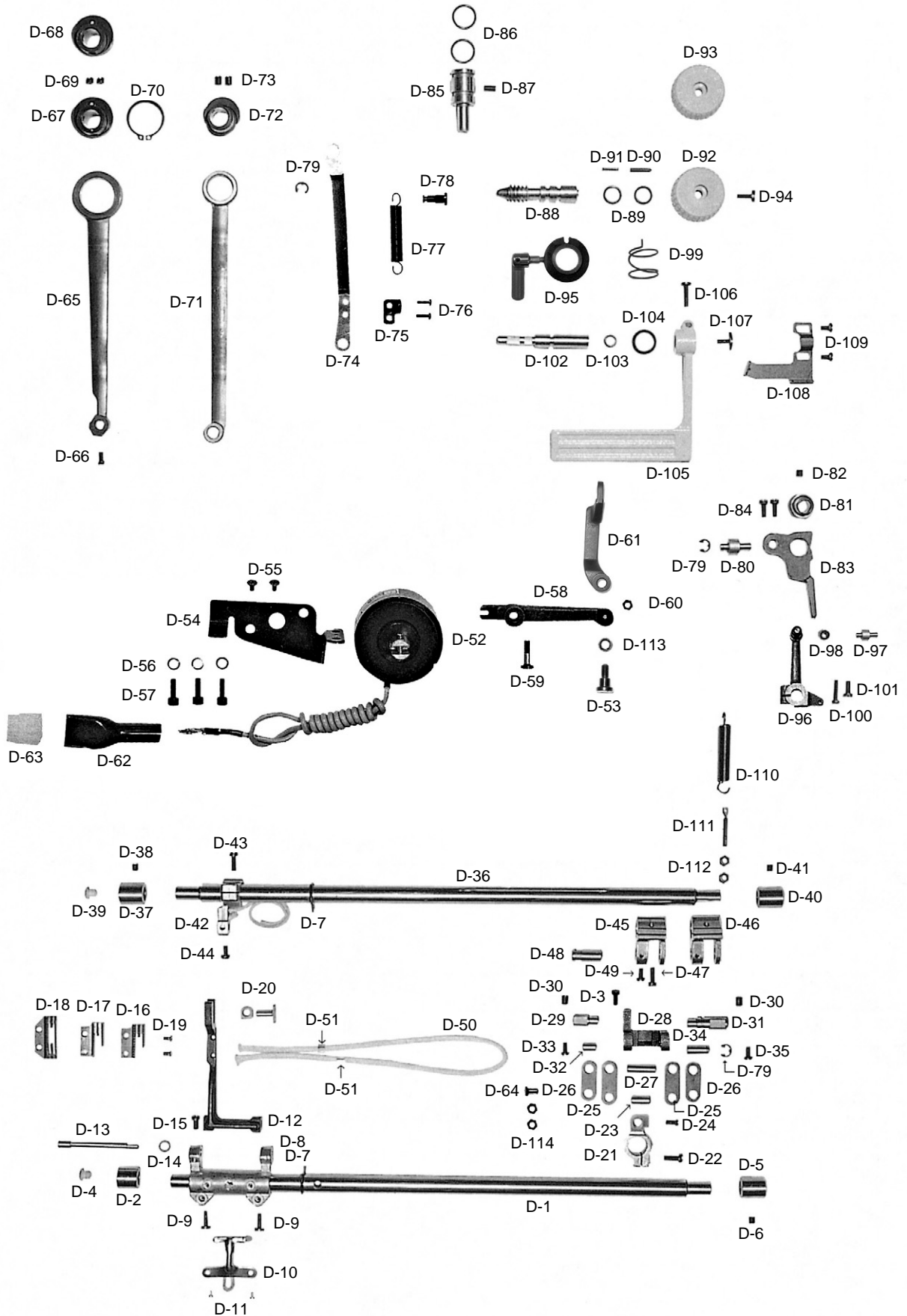

Ref. No.	Parts No.	Note	Name of Parts	품명	Q'ty	Applied Period
D-1	CLF-KF000200		Feed Roker Shaft	수평 밀대	1	
D-2	DBS-DA006700		Bushing(Front)	수평 밀대 전 붓싱	1	
D-3	DSC-BF003600		Screw(11/64"n=40)	와이롯드 보강판 나사(11/64"n=40)	1	
D-4	DPK-CB002500		Rubber Cap	들밀대 유심마개	1	
D-5	DBS-DA006800		Rear Bushing	들대 붓싱(후)	1	
D-6	DSC-CA000100		Screw(15/64"n=28)	피드캠 고정나사(15/64"n=28)	1	
D-7	CLB-FZ000100		Rubber Flange	들밀대 고무마개	2	
D-8	CLF-CB000700		Feed Rocker	뜸니 받침 크랭크	1	
D-9	DSC-BF002600		Screw(3/16"n=32)	뜸니 받침 크랭크 쥘나사(3/16"n=32)	2	
D-10	CLB-BG002300		Retainer Plate For Oil Wick	심지 지지대	1	
D-11	DSC-BF007700		Screw(1/8"n=44)	심지 지지대 나사(1/8"n=44)	2	
D-12	CLF-CR000300		Feed Bar	뜸니 받침	1	
D-13	CLF-KH000100		Feed Bar Shaft	뜸니 받침 축	1	
D-14	DWS-AA001500		Washer	뜸니 받침 축 와셔	1	
D-15	DSC-BF000400		Screw(15/64"n=28)	뜸니 받침 축 고정나사(15/64"n=28)	1	
D-16	CGA-GB000501		Feed Dog	뜸니	1	
D-17	CGA-GB001500		Feed Dog	뜸니	1	
D-18	GP-019000-00		Feed Dog(AL-Type)	뜸니(박물용)	1	
D-19	DSC-BF001800		Screw(1/8"n=44)	뜸니 쥘나사(1/8"n=44)	2	
D-20	CLF-CD000400		Sliding Block and Shaft	뜸니 받침 블럭	1	
D-21	CLF-CB000800		Crank(Rear)	수평 밀대 크랭크(후)	1	
D-22	DSC-AA001000		Screw(3/16"n=28)	들대 크랭크(전) 쥘나사(3/16"n=28)	1	
D-23	DPN-AA000100		Pin(A)	피이드 연결 링크 핀(A)	1	
D-24	DSC-BF006300	A	Screw(11/64"n=40)	하측 뒷 붓싱 쥘나사(11/64"n=40)	1	
D-25	CLF-CA000200	B	Feed Connecting Link(A)	피이드 연결 링크(A)	2	
D-26	CLF-CA000300		Feed Connecting Link(B)	피이드 연결 링크(B)	2	
D-27	DPN-AA003900		Pin(B)	피이드 연결 링크 핀(B)	1	
D-28	CFA-CA000300		Feed Regulator Link	피이드 조절 링크	1	
D-29	DPN-BC001100		Hinge Pin(B)	피이드 조절 링크 힌지 핀(B)	1	
D-30	DSC-CA001100		Screw(1/4"n=40)	실체기 핀 고정나사(1/4"n=40)	2	
D-31	DPN-BC001000		Hinge Pin(A)	피이드 조절 링크 힌지 핀(A)	1	
D-32	DPN-AA004000		Pin(C)	피이드 연결 링크 핀(C)	1	
D-33	DSC-BF003600		Screw(11/64"n=40)	와이롯드 보강판 나사(11/64"n=40)	1	
D-34	DPN-AA004100		Hinge Pin	피이드 조절 연결 로트드 힌지 핀	1	
D-35	DSC-BF003600		Screw(11/64"n=40)	와이롯드 보강판 나사(11/64"n=40)	1	
D-36	CLF-KF000100		Feed Lifting Shaft	들대	1	
D-37	DBS-DA007100		Front Bushing	들대 붓싱(전)	1	
D-38	DSC-CA000100		Screw(15/64"n=28)	들대전부싱 고정나사(15/64"n=28)	1	
D-39	DPK-CB002500		Rubber Cap	들밀대 유심마개	1	
D-40	DBS-DA006800		Rear Bushing	들대 붓싱(후)	1	

**NOTE:**

A=KM-235A  
B=KM-235B

# D

## Feed Mechanism 피이드 관계

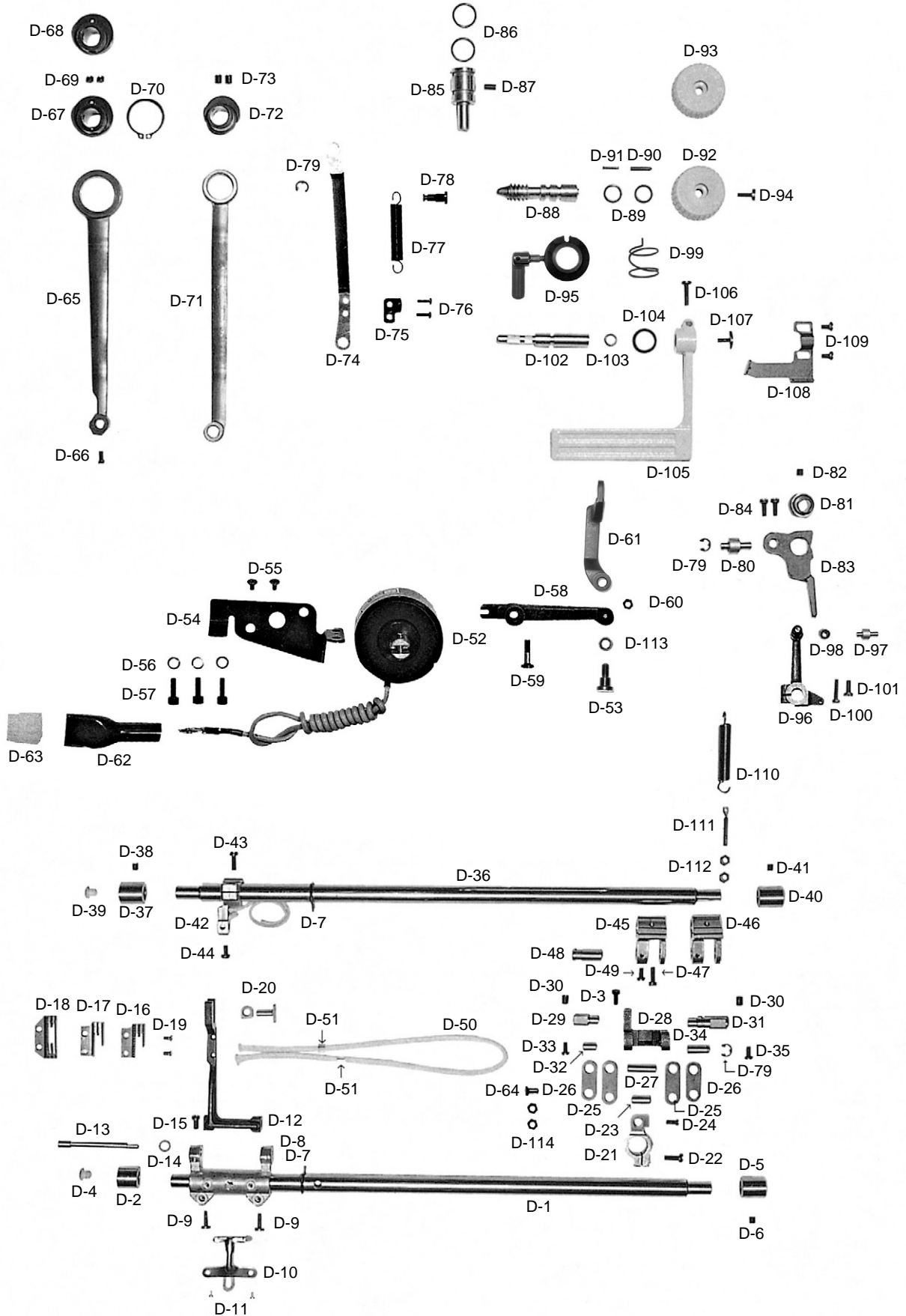



Ref. No.	Parts No.	Note	Name of Parts	품 명	Q' ty	Applied Period
D-41	DSC-CA000100		Screw(15/64"n=28)	피드 캠 고정나사(15/64"n=28)	1	
D-42	CLF-CB000500		Feed Lifting Bell Arm	들대 크랭크(전)	1	
D-43	DSC-AA001000		Screw(3/16"n=28)	들대 크랭크(전) 고정나사(3/16"n=28)	1	
D-44	DSC-BF007900		Screw(3/16"n=32)	톱니 받침 볼력 고정나사(3/16"n=32)	1	
D-45	CLF-CB000600	A	Rear Crank	들대 크랭크(후)	1	
D-46	CLF-CB003100	B	Rear Crank	들대 크랭크(후)	1	
D-47	DSC-AA001000		Screw(3/16"n=28)	들대 크랭크(전) 고정나사	1	
D-48	DPN-AA003600		Hinge Pin	들밀대 크랭크 핀	1	
D-49	DSC-BF003600		Screw(11/64"n=40)	와이롯드 보강판 나사(11/64"n=40)	1	
D-50	CLB-JD000300		Oil Wick	오일 심지	1	
D-51	CLB-BG005300		Holder For Oil Wick	오일 심지 스톱퍼	2	
D-52	DSD-AA003000		Reverse Feed Solenoid Ass'y	역진 솔레노이드(SBT-5)	1	
D-53	DSC-FA008600		Stud Screw For Connecting Rod	역진 솔레노이드 연결로드 스테드나사	1	
D-54	CFA-BB000200		Bracket For Reverse Feed Solenoid	역진 솔레노이드 브라켓	1	
D-55	DSC-BB001500		Screw(M5×0.8)	역진 솔레노이드 부착나사(M5×0.8)	2	
D-56	PWS-CA000500		Spring Washer For Bracket	싱크로 베이스 스프링 와셔(×6)	3	
D-57	PSC-AC000600		Screw(M6)	싱크로 베이스 고정볼트(M6)	3	
D-58	CFA-CB000400		Reverse Feed Solenoid Crank	역진 솔레노이드 크랭크	1	
D-59	DSC-FA006300		Stud Screw For Solenoid Crank	역진 솔레노이드 크랭크 단나사	1	
D-60	PSN-AA001700		Hinge Nut For Connecting Rod	케이블 연결너트(B)	1	
D-61	CFA-CC000302		Reverse Solenoid Connecting Rod	역진 솔레노이드 연결로드	1	Apr.29.11
D-62	11-019M-2350		Tube	솔레노이드 튜브	1	
D-63	11-018M-2350		Plug	솔레노이드 플러그	1	
D-64	DPN-AD011300		Hinge Pin For Connecting Rod	역진 솔레노이드 연결로드 힌지핀	1	
D-65	CLF-CC000100		Feed Rocker Shaft Connecting Rod	수평 이송 로드	1	
D-66	DSC-BF006300		Screw(11/64"n=40)	하측휫 B/S 콕나사(11/64"n=40)	1	
D-67	CLF-DC001700	A	Feed Cam(A)	피이드 캠(A)	1	
D-68	CLF-DC002200	B	Feed Cam(B)	피이드 캠(B)	1	
D-69	DSC-CA001900		Screw(1/4"n=40)	기어나사(5-16) (1/4"n=40)	2	
D-70	PSR-AA000400		Stopper C-Ring	스냅링(∅28)	1	
D-71	CLF-CC000200		Crank Rod Complete	크랭크 로드	1	
D-72	CLF-DC001800		Feed Cam(C)	피이드 캠(C)	1	
D-73	DSC-CA001100		Screw(1/4"n=40)	실채기 핀 고정나사(1/4"n=40)	2	
D-74	CFA-CC000200		Connecting Rod For Feed Regulator	피이드 조절 로드	1	
D-75	CFA-BJ000300		B/T Spring Holder	자동 역진 스프링 홀더	1	
D-76	DSC-BJ000300		Screw(9/64"n=40)	톱카바 나사(우)(9/64"n=40)	2	
D-77	DSP-AB004800		Reverse Feed Spring	역진 레버 스프링	1	
D-78	DSC-FH000500		Holder For Reverse Feed Spring	자동 역진 스프링 걸이	1	
D-79	PSR-AC000200		E-Ring	E-링(∅5)	3	
D-80	CFA-KF000300		Feed Adjusting Shaft	피이드 조절축	1	

**NOTE:**

A=KM-235A  
B=KM-235B

# D

## Feed Mechanism 피이드 관계

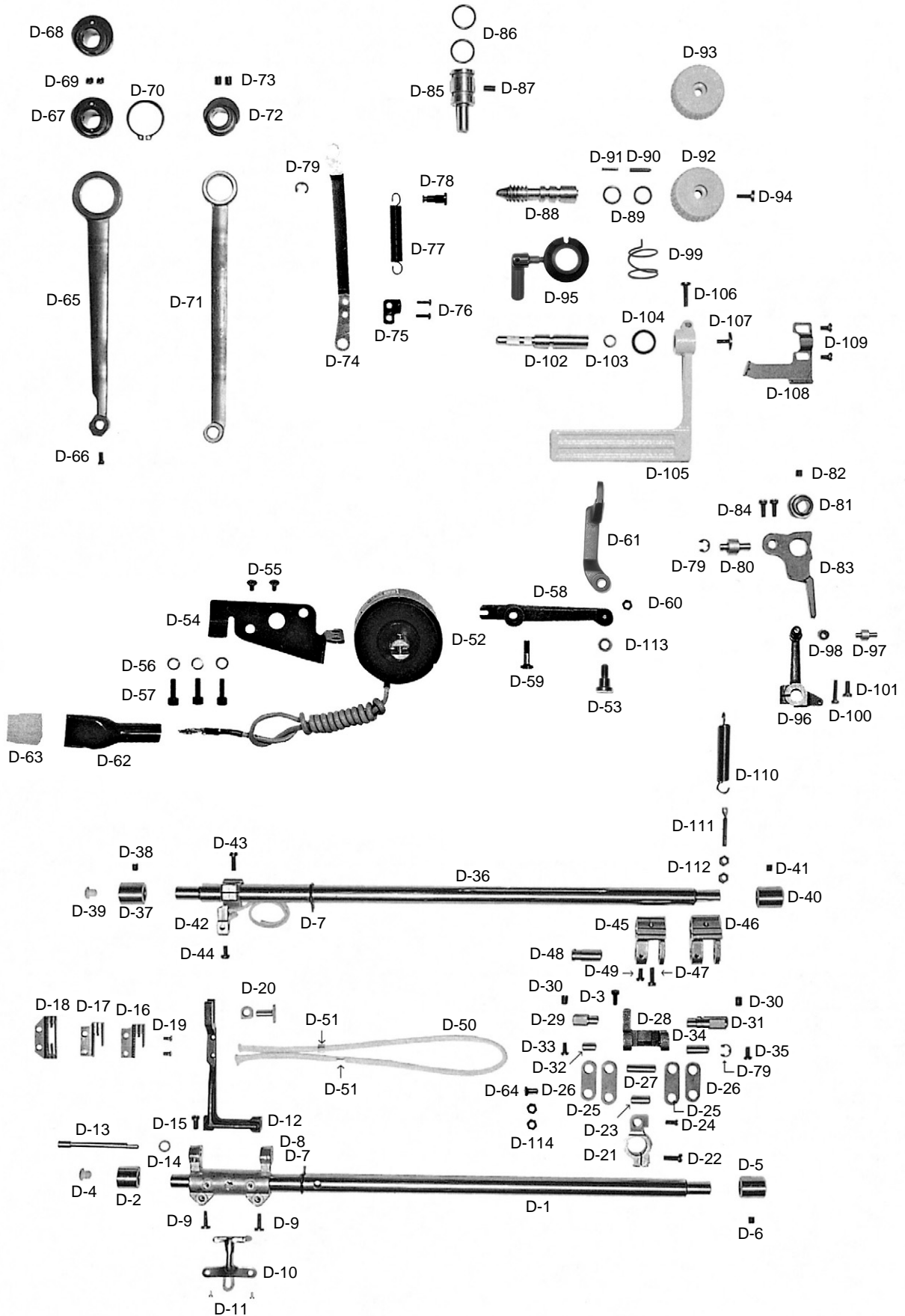

Ref. No.	Parts No.	Note	Name of Parts	품 명	Q' ty	Applied Period
D-81	DCL-AA002800		Collar	피이드 조절기 축 카라	1	
D-82	DSC-CA000500		Screw(1/4" n = 40)	홈볼이 멈춤나사(1/4" n = 40)	1	
D-83	CFA-DF000101		Feed Regulating	피이드 조절기	1	
D-84	DSC-BF001000		Screw(11/64" n = 40)	홈볼이 납작 작은나사(11/64" n = 40)	2	
D-85	CFA-KF000201		Shaft	피이드 조절기 축	1	
D-86	PPK-BA000800		O-Ring	피이드 조절기 붓싱 오링	2	
D-87	DSC-CA000800		Screw(15/64" n = 28)	상축 B/S 고정나사(15/64" n = 28)	1	
D-88	CFA-KJ001100		Feed Regulator Dial Shaft	피이드 조절 다이알축	1	
D-89	PPK-BA000900		O-ring	다이알 축 오링	2	
D-90	DPN-AA014100		Dial Pin	다이알 핀	1	
D-91	DSP-AA002800		Feed Regulator Dial Spring	다이알 스프링	1	
D-92	CFA-CQ001100		Feed Regulating Dial-Insert Type	다이알 판(조)	1	
D-93	CFA-CQ001300		Feed Regulating Dial-Insert Type	다이알 판(조)	1	
D-94	DSC-BF001900		Screw(3/16" n = 28)	다이알 판 고정나사(3/16" n = 28)	1	
D-95	AFA-PS000100		Dial Shaft Locker A' ssy	다이알축 잠금장치(조)	1Set	
D-95-1	CFA-BN000100		Dial Shaft Holder	다이알축잡이	1	
D-95-2	CFA-BN000200		Dial Shaft Holder Body	다이알축잡이몸체	1	
D-95-3	CFA-BM000100		Dial Shaft Stopper	다이알축스토퍼	1	
D-95-4	CFA-CM000300		Dial Shaft Stopper Handle	다이알축스토퍼 손잡이	1	
D-95-5	PPN-AF001000		Spring Pin	스프링핀 $\varnothing 2.5 \times L10$	1	
D-96	CFA-CB0003300		Feed Regulator Arm	역진 레버 크랭크(조)	1Set	
D-97	DPN-BC003900		Pin	역진 레버 크랭크 로올러 핀	1	
D-98	CFA-CL000200		Roller	역진 레버 크랭크 로올러 고무	1	
D-99	DSP-AA005200		Spring	다이알축 편심스프링	1	
D-100	DSC-BA000400		Screw(3/16" n = 28)	수평밀대 크랭크 쥘나사(3/16" n = 28)	1	
D-101	DSC-BF003100		Screw(11/64" n = 40)	가마잡이 나사(11/64" n = 40)	1	
D-102	CFA-KF000100		Shaft	역진 레버축	1	
D-103	PPK-BA000700		Packing	레버축 오링	1	
D-104	DWS-CB000200		Corrugated Washer	레버 와셔	1	
D-105	CFA-CM001300		Reverse Feed Control Lever	역진 레버	1	
D-106	DSC-BA001400		Screw(3/16" n = 32)	역진 레버 고정나사(3/16" n = 32)	1	
D-107	DSC-BJ002400		Screw(3/16" n = 32)	레버 덮개 나사(3/16" n = 32)	1	
D-108	CFA-BB001300		Stopper	역진 레버 스토퍼	1	
D-109	DSC-BJ003500		Screw(11/64" n = 40)	슬레노이드 부착 커버 고정나사(11/64" n = 40)	2	
D-110	DSP-AB003500		Spring	역진 레버 스프링	1	
D-111	DSC-HD000600		Adjusting Screw	스프링 걸이 축나사	1	
D-112	DSN-AA000900		Nut(11/64" n = 40)	S/P 걸이 축 나사 너트(11/64" n = 40)	2	
D-113	WS-000630-00		Rubber Washer	고무와셔	1	
D-114	PSN-AA003100		Nut	너트	2	

**NOTE:**

A=KM-235A  
B=KM-235B

## Press bar & Tension Release Mechanism 누름대 및 실 늦추기 관계

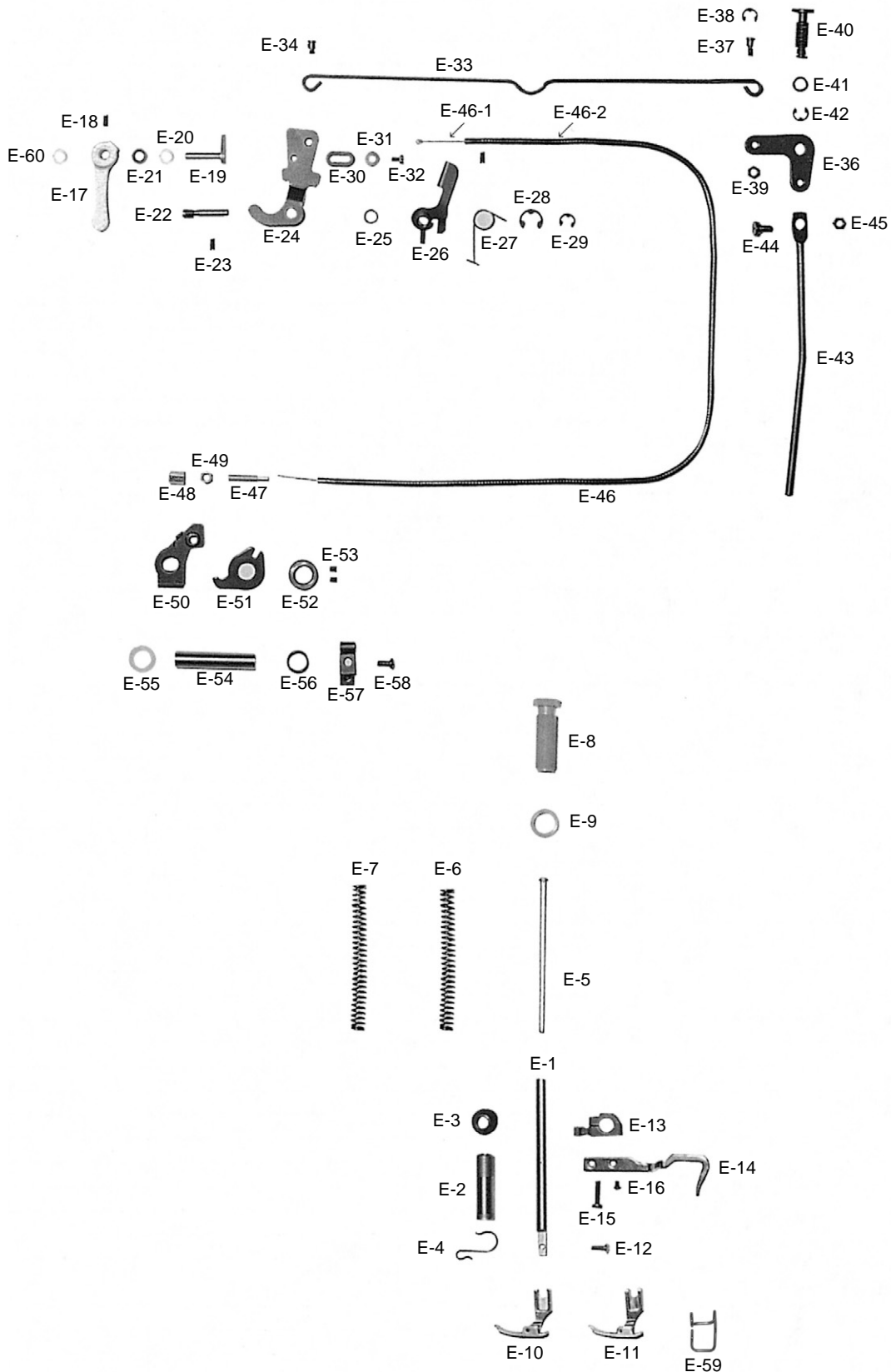

Ref. No.	Parts No.	Note	Name of Parts	품명	Q'ty	Applied Period
E-1	CPB-KB000100		Presser Bar	누름대	1	
E-2	DBS-DA018200		Bushing	누름대 붓싱	1	
E-3	DPK-CZ000600		Rubber Cap	누름대 붓싱 캡	1	
E-4	CLB-BH000300		Retainer For Oil Tube	환류 파이프 잡이	1	
E-5	CPB-KC000300		Presser Regulator Bar	압력 조절봉	1	
E-6	DSP-AA010300	A	Presser Regulation Spring	압력 조절 스프링	1	
E-7	DPSP-AA010800	B	Presser Regulation Spring	압력 조절 스프링	1	
E-8	DSC-HA000100		Screw(9/16"n = 20)	압력 조절나사(9/16"n = 20)	1	
E-9	DSN-CC000100		Presser Adjusting Nut	압력 조절나사 너트	1	
E-10	CGA-GC000701	A	Hinged Foot Complete	노루발(조)	1Set	
E-11	AGA-PS002200	B	Hinged Foot Complete	노루발(조)	1Set	
E-12	DSC-BA000200		Screw(9/64"n = 40)	홈볼이 냄비 작은나사(9/64"n = 40)	1	
E-13	CPB-BF000400		Holder	누름대 잡이	1	
E-14	CPB-HK000101		Thread Guide For Frame	실걸이 판	1	
E-15	DSC-BF001200		Screw(11/64"n = 40)	가마잡이 나사(11/64"n = 40)	1	
E-16	DSC-BJ001400		Screw(9/64"n = 40)	윗투경 고정판 고정나사(9/64"n = 40)	1	
E-17	CPB-CM000300		Presser Bar Lifter Lever	누름대 올리기	1	
E-18	DSC-BJ000300		Screw(11/64"n = 40)	뜸니 커버 나사(우)	1	
E-19	CPB-DF000700		Cam Shaft	누름대 올림기 캠축	1	
E-20	DWS-AA003800		Felt Washer	상축 felt 와셔	1	
E-21	DWS-AA003800		Washer	실 낮추기 축 와셔	1	
E-22	CTR-KC000500		Shaft	실 낮추기 축	1	
E-23	DSC-CB000300		Screw(11/64"n = 40)	하축 중 베어링 고정나사(11/64"n = 40)	2	
E-24	CPM-CM002300		Knee Lifter Plate	노루발 인상판	1	
E-25	PWS-AA003500		Washer	실 낮추기 축 와셔	1	
E-26	ATR-PS000200		Thread Tension Release Plate	실 낮추기(조)	1	
E-27	DSP-AC005800		Spring	실 낮추기 스프링	1	
E-28	PSR-AC000800		E-Ring	실 낮추기 안내 붓싱 E링(Ø8)	1	
E-29	PSR-AC000200		E-Ring	E-링(Ø5)	1	
E-30	CTR-BB001100		Stopper	실 낮추기 스토퍼	1	

**NOTE:**

A=KM-235A  
B=KM-235B

## Press bar & Tension Release Mechanism 누름대 및 실 늦추기 관계

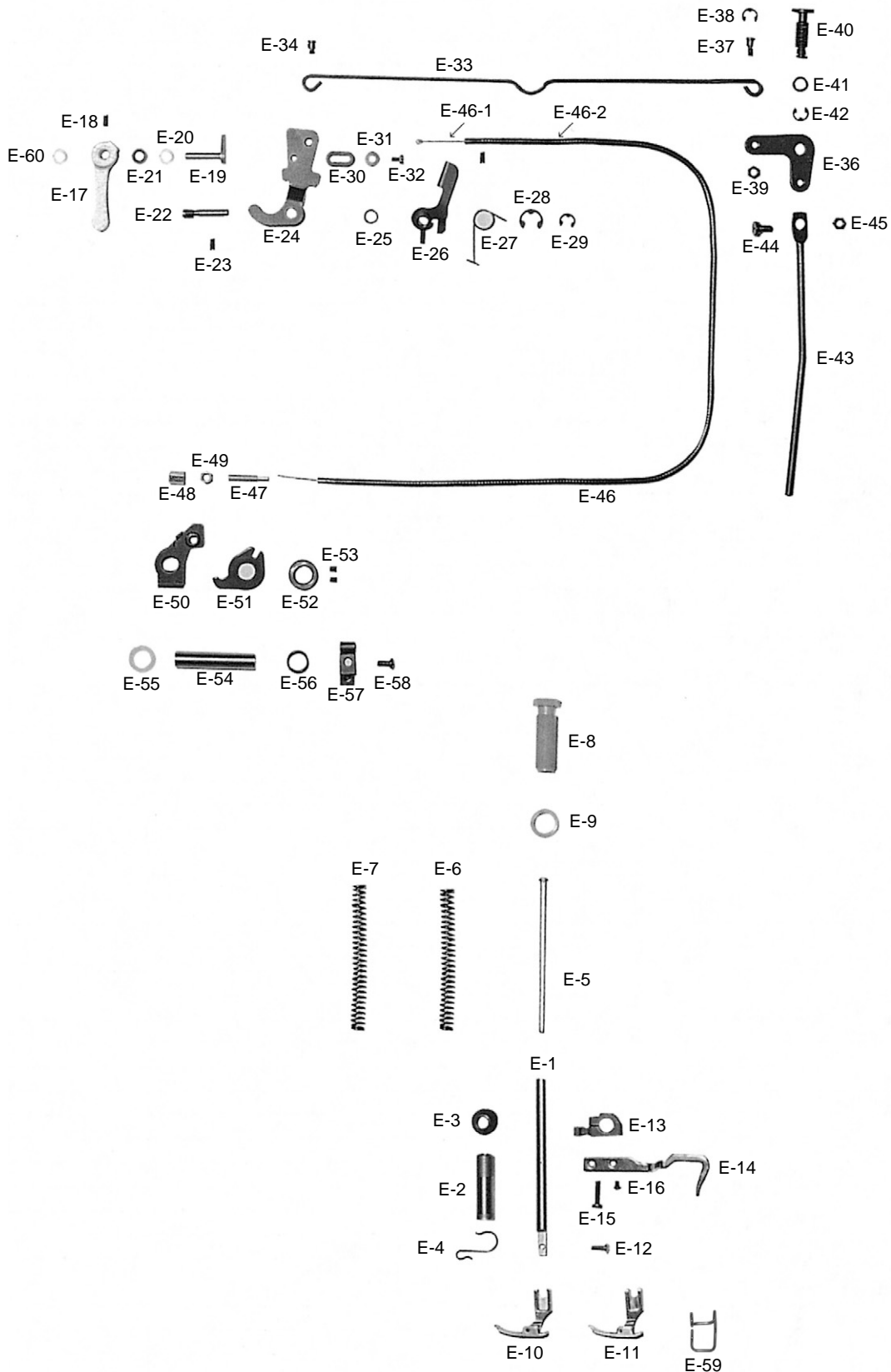

Ref. No.	Parts No.	Note	Name of Parts	품 명	Q' ty	Applied Period
E-31	DWS-AA000500		Washer	실 낮추기 스톱퍼 와셔	1	
E-32	DSC-AA003300		Screw(9/64"n = 40)	실 낮추기 스톱퍼 쥘나사(9/64"n=40)	1	
E-33	CPM-BH000900		Connecting Rod	누름대 올리기 연결봉	1	
E-34	SC-001912-00		Hinge Screw For Knee Lefter Plate	누름대 올리기 연결봉 단나사	1	
E-36	CPM-CA001700		Knee Lifting Link	무릎 올림 링크	1	
E-37	DSC-FF002300		Hinge Screw	누름대 올리기 연결봉 단나사(대)	1	
E-38	PSR-AC000200		E-Ring	E-링(∅5)	1	
E-39	DSN-AA000600		Nut(3/16"n = 32)	오프너 너트(3/16"n=32)	1	
E-40	DSC-FH000900		Hinge Screw	무릎 올림 링크 힌지나사	1	
E-41	PPK-BA000500		O-Ring	역진 레버 축 오링	1	
E-42	PSR-AC000200		E-Ring	E-링(∅5)	1	
E-43	CPM-CR000901		Knee Lifting Rod	무릎 올림 봉	1	
E-44	DSC-FA018800		Hinge Screw	무릎 올림 봉 단나사	1	
E-45	DSN-AA000600		Nut(3/16"n = 32)	오프너 너트(3/16"n=32)	1	
E-46	ATR-PS000300		Tension Release Cable	실 낮추기 케이블(조)	1Set	
E-46-1	AS-000042-00		Wire Rope	와이어 로우프	1	
E-46-2	AS-000042-00		Cable	실 낮추기 케이블	1	
E-47	DSC-HZ001100		Connecting Bolt	케이블 연결 볼트	1	
E-48	DSN-AA002400		Nut(A)	케이블 연결 너트(A)	1	
E-49	PSN-AA001700		Nut(B)	케이블 연결 너트(B)	1	
E-50	CTR-CM001200		Operating Lever For Thread Release	실 낮추기 작동 레버	1	
E-51	CTR-CM001300		Cam Driving Lever	캠 접촉 레버	1	
E-52	DCL-AA008200		Collar	캠 접촉 카라	1	
E-53	DSC-CB000700		Screw(M5)	캠 접촉 카라 고정나사(M5)	1	
E-54	CTR-BQ000200		Pipe For Thread Release Lever	실 낮추기 레버 파이프	1	
E-55	DWS-AA016700		Flat Washer	평 와셔	1	
E-56	PPK-BA000900		O-Ring	오링(P11)	1	
E-57	DTC-AH001200		Cable Clip(A)	케이블 클립(A)	1	
E-58	DSC-BA000700		Screw(3/16"n = 32)	톱니 받침 볼력 고정나사(3/16"n=32)	1	
E-59	CPB-BH000600		Safety Guide	안전 가이드	1	
E-60	DWS-AA000500		Washer	평와셔	1	

**NOTE:**

A=KM-235A  
B=KM-235B

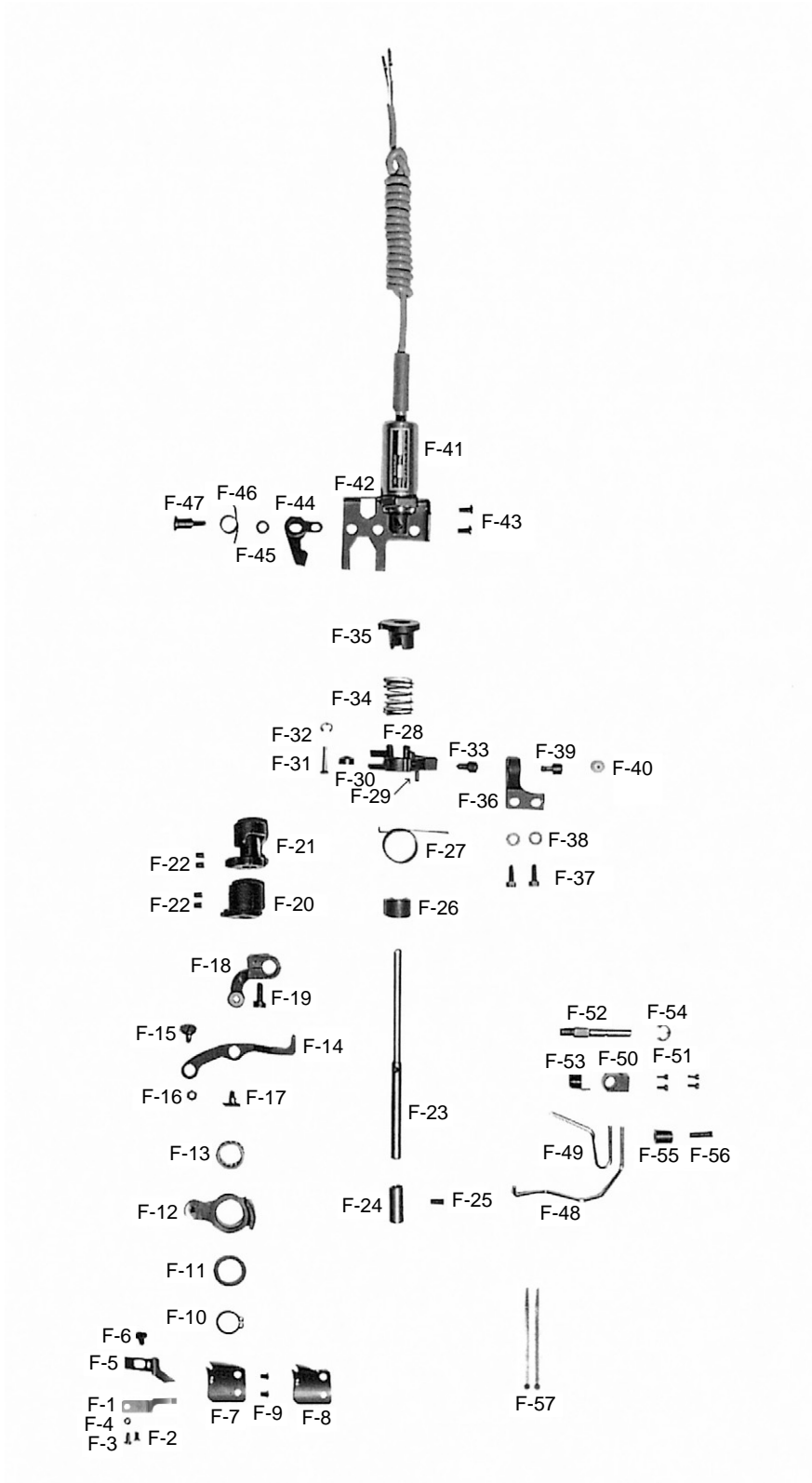



Ref. No.	Parts No.	Note	Name of Parts	품명	Q'ty	Applied Period
F-1	CTT-NB000901		Fixed Mes	고정메스	1	
F-2	DSC-BB002000		Screw(9/64"n=40)	고정메스 고정나사(9/64"n=40)	1	
F-3	DSC-BF006200		Screw(1/8"n=40)	고정메스 장력 조절나사(1/8"n=40)	1	
F-4	DSN-AA001700		Nut(1/8"n=40)	고정메스 장력 조절나사 너트(1/8"n=40)	1	
F-5	CTT-BJ001100		Thread Detachable Plate	실 가리개	1	
F-6	DSC-BJ003500		Screw(11/64"n=40)	슬레노이드 부록 커버 고정나(11/64"n=40)	1	
F-7	CTT-NA000600	A	Rotary Mes	회전메스	1	
F-8	CTT-NA001000	B	Rotary Mes	회전메스	1	
F-9	DSC-BB001400		Screw(11/64"n=40)	회전메스 고정나사(11/64"n=40)	2	
F-10	PSR-AA000100		Stopper C-Ring	스냅링(∅15)	1	
F-11	DWS-AA005100		Washer	사절 홀더 와셔	1	
F-12	CTT-BF001700		Holder	사절 홀더	1	
F-13	PBR-BA001200		Needle Bearing	니들 베어링	1	
F-14	CTT-CA001700		Connecting Link	연결 링크	1	
F-15	DSC-FA019400		Pivot Screw	연결 링크 단나사(대)	1	
F-16	DSN-AA000900		Nut(11/64"n=40)	S/P 절이축 나사 너트(11/64"n=40)	1	
F-17	DSC-FA019300		Pivot Screw	연결 링크 단나사(소)	1	
F-18	CTT-CM002900		Thread Trimmer Lever	사절 레버	1	
F-19	DSC-BF000700		Screw(15/64"n=28)	베이스 고정나사 B(15/64"n=28)	1	
F-20	CTT-DF000501		Reversal Cam	역전캠(K1895)	1	Dec.29.10
F-21	DGR-AA003001		Thread Trimmer Gear Assembly	사절 기어(조)	1set	Feb.01.11
F-22	DSC-CB000500		Screw(15/64"n=28)	캠 접촉안내 고정나사(15/64"n=28)	4	
F-23	CTT-KF000700		Thread Trimmer Shaft	사절 축	1	
F-24	DBS-DA020000		Bushing	사절 축 붓싱	1	
F-25	DSC-CA000800		Screw(15/64"n=28)	상축 B/S 고정나사(15/64"n=28)	1	
F-26	CTT-BN000500		Spring Guide	스프링 안내	1	
F-27	DSP-AC006400		Spring	스토퍼 레버 스프링	1	
F-28	CTT-CM003100		Stopper Lever	스토퍼 레버	1	
F-29	PPN-AF003000		Stopper Pin	스토퍼 핀(3×14)	1	

**NOTE:**

A=KM-235A  
B=KM-235B

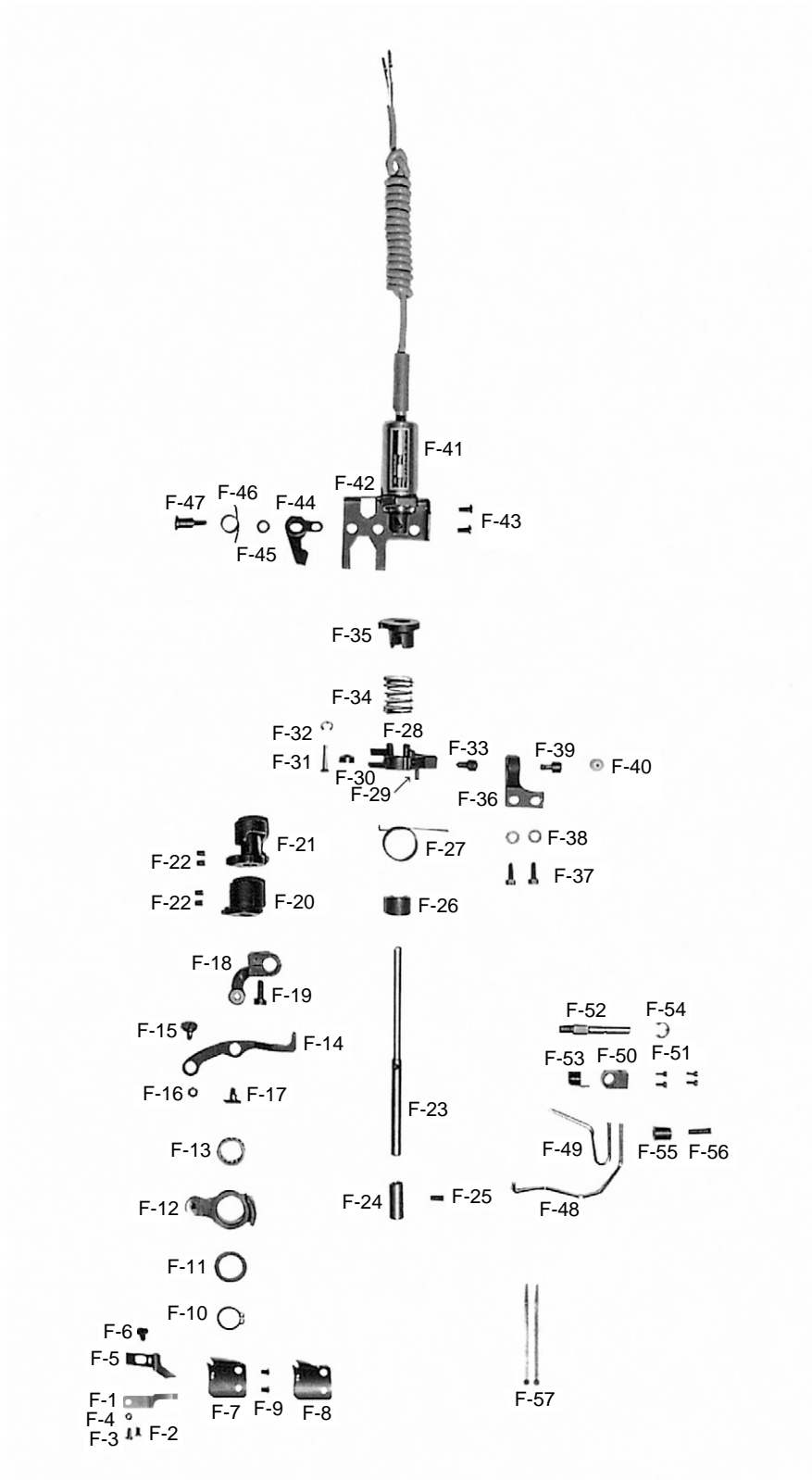

Ref. No.	Parts No.	Note	Name of Parts	품 명	Q' ty	Applied Period
F-30	DCL-BB002500		Collar	스토퍼 레버 카라	1	
F-31	DPN-AD009200		Collar Shaft	스토퍼 레버 카라 축	1	
F-32	PSR-AC000300		Stop Ring	인상판 E링(∅4)	1	
F-33	DSC-AC002200		Screw(1/4"n=40)	스토퍼 레버 고정나사(1/4"n=40)	1	
F-34	DSP-AA010400		Spring	사절구동기어(B)스프링	1	
F-35	DGR-AA003101		Thread Trimmer Gear "B"	사절구동기어(B)(K1896)	1	Feb.01.11
F-36	CTT-BB002900		Stopper	스토퍼(K1886)	1	
F-37	DSC-AA003000		Screw(3/16"n=32)	스토퍼 쥘나사(3/16"n=32)	2	
F-38	DWS-AA000600		Washer	스토퍼 쥘 와셔	2	
F-39	CTT-FD000300		Cushion Rubber (A)	스토퍼 쿠션 고무	1	
F-40	CTT-FZ000100		Cushion Rubber	쿠션 고무	1	
F-41	DSD-AA003200		Trimmer Solenoid Assembly	사절 솔레노이드(조)	1Set	
F-42	CTT-BB003100		Solenoid Base	솔레노이드 받침	1	
F-43	DSC-BA000700		Screw(3/16"n=32)	톱니 받침 블럭 고정나사(3/16"n=32)	2	
F-44	CTT-CM003000		Clutch Lever	클러치 레버	1	
F-45	DWS-AA000600		Washer	스토퍼 쥘 와셔	1	
F-46	DSP-AC006500		Spring	클러치 스프링	1	
F-47	DSC-FA019000		Pivot Screw	클러치 레버 단나사	1	
F-48	CTT-BH000101		Bobbin Presser Bar	보빈 압력봉	1	
F-49	CTT-BH000600		Lever	레버	1	
F-50	CTT-BF000200		Holder	레버잡이	1	
F-51	DSC-BF000100		Screw(1/8"n=44)	바늘대 실걸이 쥘나사(1/8"n=44)	4	
F-52	DSC-HC000400		Bed Leg Rear	베드 받침(전)	1	
F-53	DSP-AC001700		Spring	보빈 압력 스프링	1	
F-54	PSR-AC000500		E-Ring(∅6)	E링(∅6)	1	
F-55	CTT-FD000100		Stopper Rubber	보빈 압력봉 스토퍼	1	
F-56	DSC-CA001500		Screw(15/64"n=28)	폴리 고정나사(15/64"n=28)	1	
F-57	PTC-AG000100		Nylon Clip	나일론 클립	2	

**NOTE:**

A=KM-235A  
B=KM-235B



# Reverse Button Mechanism

## 역진 버튼 관계

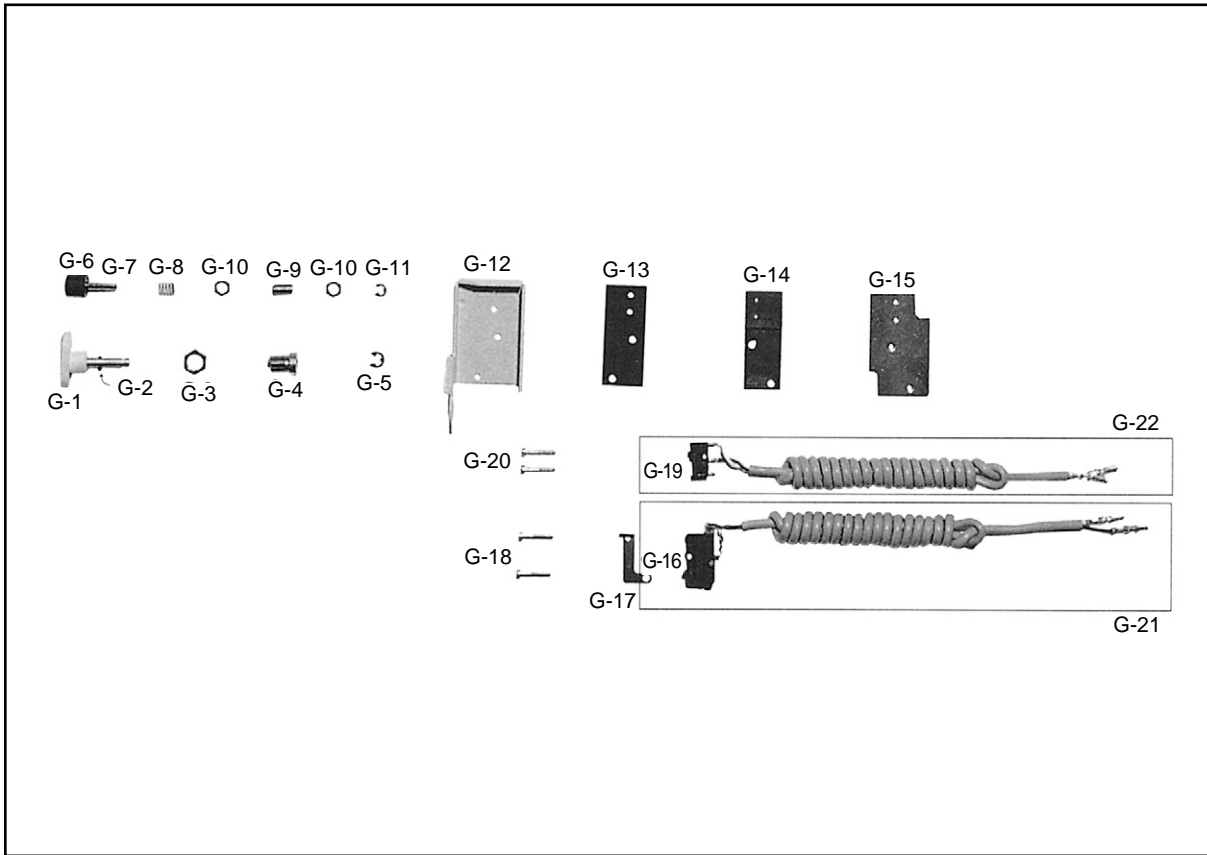

Ref. No.	Parts No.	Note	Name of Parts	품 명	Q' ty	Applied Period
G-1	ARB-PS000700		Reverse Button Ass'y	역진버튼(조)	1Set	
G-2	PPN-AF000900		Stopper Pin(2×8)	롤핀(2×8)	1	
G-3	DSN-AA003800		Nut	역진 버튼 축 안내 붓싱 캡너트	1	
G-4	DBS-DB008100		Guide Bushing	역진 버튼 축 안내붓싱	1	
G-5	PSR-AC000300		Stop Ring	인상판 E링(∅4)	1	
G-6	CRB-BK000300		Reverse Selection Button	버튼(B)	1	
G-7	CRB-KC000200		Shaft	버튼 지지축	1	
G-8	DSP-AA010500		Spring	버튼(B) 완충 스프링	1	
G-9	12-006S-2700		Support Screw	버튼 지지나사	1	
G-10	DSN-AA003900		Nut	버튼 지지나사 캡너트	2	
G-11	PSR-AC000400		E-Ring	톱니 받침 블록 축 E링(∅3)	1	
G-12	CRB-LC000400		Button Case	버튼 케이스	1	
G-13	CRB-FD000200		Insulated Rubber(B) For Switch	스위치 받침 절연고무(B)	1	
G-14	CRB-FD000300		Insulated Rubber (A) For Switch	스위치 받침 절연고무(A)	1	
G-15	CRB-LA000100		Cover	버튼 케이스 커버	1	
G-16	12-009C-2700		Reverse Button Switch	역진 버튼 스위치	1	
G-17	CRB-BJ000500		Pushing Plate	역진 버튼 스위치 누름판	1	
G-18	DSC-BJ005800		Screw(1/8"n=44)	스위치 고정볼트(1/8"n=44)	2	
G-19	12-004A-2700		Reverse Selection Switch	스위치	1	
G-20	DSC-BJ005700		Screw(M2×0.4)	스위치 고정볼트 B(M2×0.4)	2	
G-21	12-009C-2700		Reverse Selection Switch Ass'y	역진 버튼 스위치	1	
G-22	12-104A-2700		Reverse Selection Switch Ass'y	역진 버튼 스위치	1	

**NOTE:**

A=KM-235A  
B=KM-235B

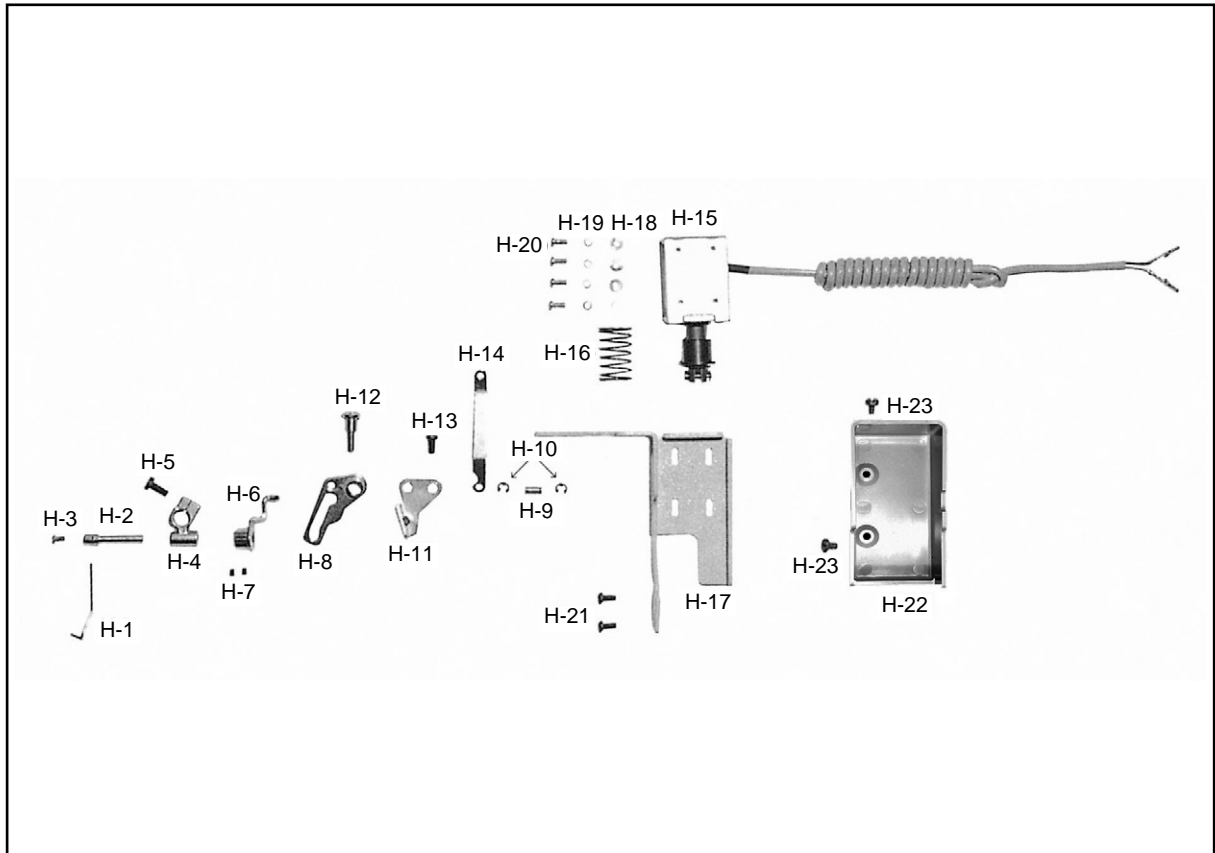

Ref. No.	Parts No.	Note	Name of Parts	품명	Q'ty	Applied Period
H-1	CWP-BH001100		Wiper	와이퍼	1	
H-2	CWP-KF000100		Wiper Rotary Shaft	와이퍼 회전축	1	
H-3	DSC-BF001800		Screw(1/8"n = 44)	톱니 쥘나사(1/8"n = 44)	1	
H-4	CWP-BF000500		Holder	와이퍼 회전축 잡이(K1900)	1	
H-5	DSC-BF003100		Screw(11/64"n = 40)	가마잡이 나사(11/64"n = 40)	1	
H-6	CWP-CB000800		Wiper Crank	와이퍼 크랭크	1	
H-7	SC-A104-4517		Screw(11/64-40-5)	육각구멍볼이 멈춤나사(11/64")	2	
H-8	CWP-BJ001400		Crank Rotary Plate	크랭크 회전판	1	
H-9	DPN-AA014200		Hinge Pin	크랭크 회전판 힌지핀	1	
H-10	PSR-AC000400		E-Ring	톱니 받침 볼록축 E링(Ø3)	2	
H-11	CWP-BA000100		Crank Rotary Regulator Plate	크랭크 회전 조절판	1	
H-12	DSC-FA019100		Hinge Screw	와이퍼 크랭크 힌지 단나사	1	
H-13	DSC-BA000700		Screw(3/16"n = 32)	톱니 받침 볼록 고정나사(3/16"n = 32)	1	
H-14	CWP-CA001900		Connecting Rod	회전판 연결 로드	1	
H-15	11-015A-2700		Wiper Solenoid Assembly	와이퍼 솔레노이드(조)	1Set	
H-16	DSP-AA010600		Solenoid Tension Spring	솔레노이드 스프링	1	
H-17	CWP-BB001500		Solenoid Bracket	솔레노이드 부착 브라켓	1	
H-18	PWS-AA000500		Flat Washer	솔레노이드 부착 평와셔	4	
H-19	PWS-CA000100		Spring Washer	솔레노이드 부착 스프링 와셔	4	
H-20	PSC-BA000100		Screw(M3×0.5)	솔레노이드 부착 고정나사(M3×0.5)	4	
H-21	DSC-BF003600		Screw(11/64"n = 40)	와이퍼 보강판 나사	2	
H-22	CWP-LA000500		Cover	솔레노이드 부착 커버	1	
H-23	DSC-BA000100		Screw(9/64"n = 40)	오일펌프 커버나사(9/64"n = 40)	2	

**NOTE:**

A=KM-235A  
B=KM-235B

# Lubrication

## 급유 관계

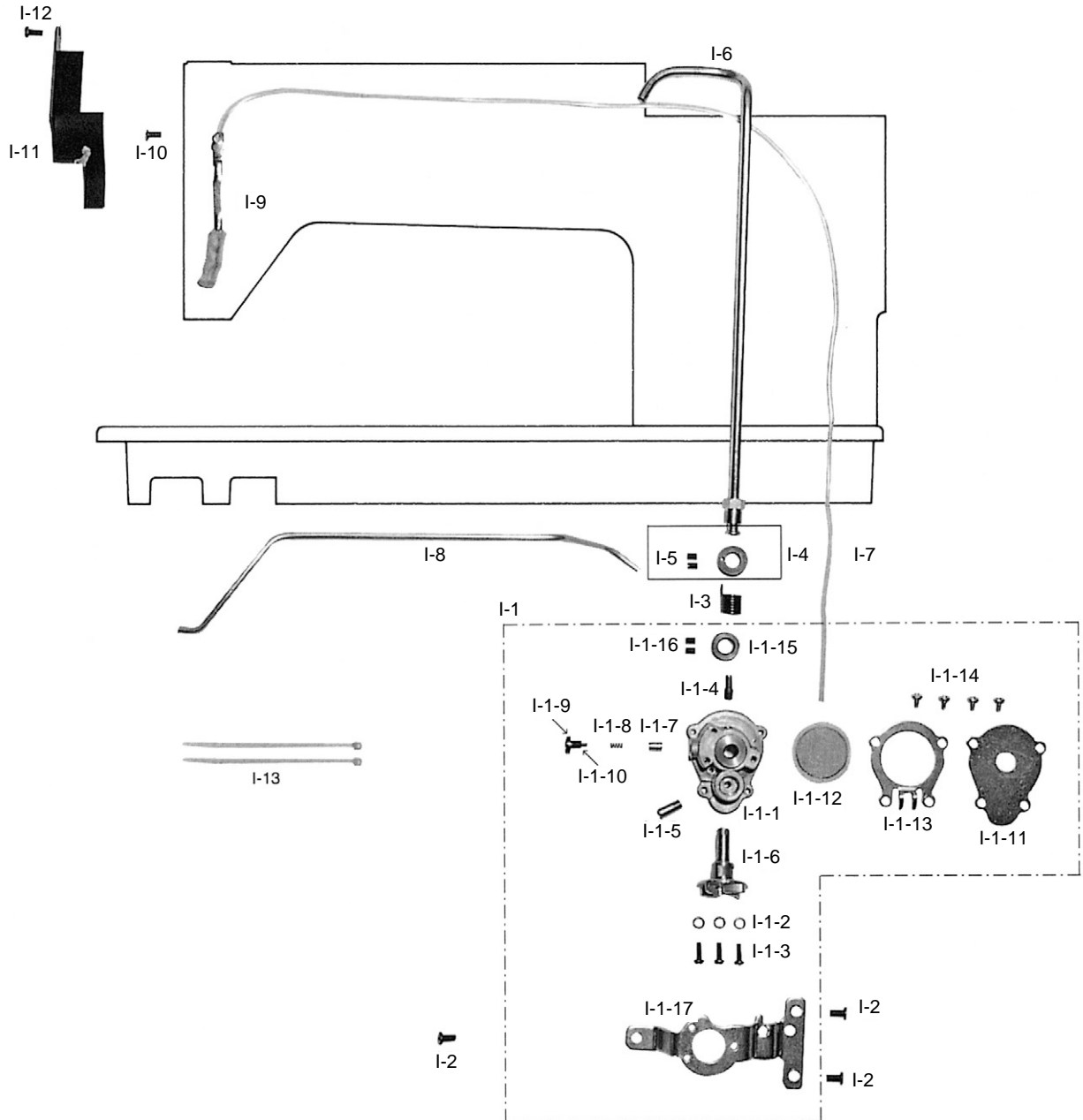

Ref. No.	Parts No.	Note	Name of Parts	품 명	Q'ty	Applied Period
I-1	ALB-PS002200		Oil Pump Ass' y	오일펌프(조)	1Set	
I-1-1	CLB-JC000200		Oil Pump Body	오일펌프 몸체	1	
I-1-2	PWS-CA000200		Washer	오일 펌프 몸체 겹나사 와셔	3	
I-1-3	DSC-BJ000300		Screw(9/64"n = 40)	톱니 커버 나사(우)(9/64"n=40)	3	
I-1-4	CLB-JP000501		Nipple For Oil Return Pipe	환류 파이프 니플	1	Jun. 08. 10
I-1-5	CLB-JP000601		Nipple For Lower Shaft	하축 급유 니플	1	Apr. 29. 10
I-1-6	CLB-BR000100		Impeller	임펠라	1	
I-1-7	CLB-CN000200		Piston	피스톤	1	
I-1-8	DSP-AA002700		Piston Spring	피스톤 스프링	1	
I-1-9	DSC-BF007400		Pin Screw	피스톤 스프링핀 나사	1	
I-1-10	PPN-AF000900		Pin	피스톤 스프링핀(RP2×8)	1	
I-1-11	CLB-LB000100		Oil Pump Cover	오일펌프 커버	1	
I-1-12	CLB-JM000400		Oil Pump Cap	오일 펌프 헬트 캡	1	
I-1-13	CLB-BG002100		Magnet Holder	자석 잡이	1	
I-1-14	44-120S-1230		Screw(11/64"n = 40)	오일 펌프 커버 나사(11/64"n=40)	4	
I-1-15	DCL-AA001500		Collar For Impeller Shaft	오일 펌프 카라	1	
I-1-16	DSC-CA000400		Screw(11/64"n = 40)	오일 펌프 조인트 나사(11/64"n=40)	2	
I-1-17	CLB-BB001700		Oil Pump Bracket	오일 펌프 브라켓	1	
I-2	DSC-BF000600		Screw(3/16"n = 28)	다이알 판 겹나사(3/16"n=28)	3	
I-3	DSP-AC002300		Spring Joint	오일 펌프 조인트 스프링	1	
I-4	DCL-AA002600		Collar	오일 펌프 조인트 카라	1	
I-5	DSC-CA000400		Screw(11/64"n = 40)	오일 펌프 조인트 나사(11/64"n=40)	2	
I-6	ALB-PS002300		Main Shaft Oil Pipe Ass' y	상축 급유 파이프	1	
I-7	CLB-JG000300		Oil Return Tube	환류 파이프	1	
I-8	CLB-JF002200		Lower Shaft Oil Pipe	하축 급유 파이프	1	
I-9	CLB-BG002200		Holder	환류 파이프 잡이	1	
I-10	DSC-BF003600		Screw(11/64"n = 40)	와이롯드 보강판 나사(11/64"n=40)	1	
I-11	CLB-BJ000400		Oil Shield	면판 유방판	1	
I-12	DSC-BA000300		Screw(11/64"n = 40)	테이프 안내 겹나사(11/64"n=40)	1	
I-13	PTC-AG000100		Nylon Clip	나이론 클립	2	

**NOTE:**

A=KM-235A  
B=KM-235B

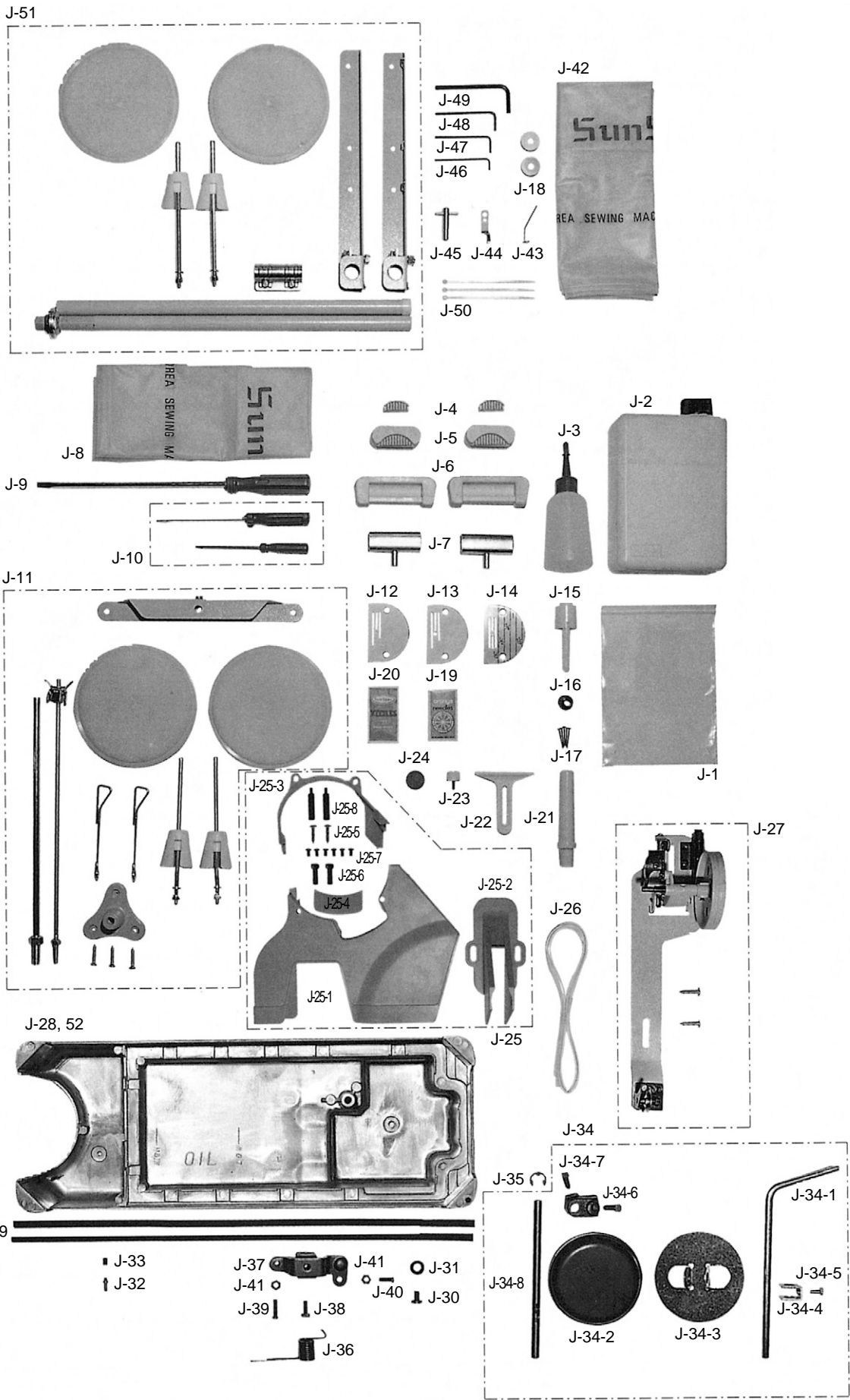



Ref. No.	Parts No.	Note	Name of Parts	품명	Q'ty	Applied Period
J-1	CAC-MH000100		Accessory Box	악세서리 박스	1	
J-2	CAC-MD000300		Oil	오일 캔	1	
J-3	CAC-JB000100		Oil Tank	유차	1	
J-4	CST-FD001200		Head Support Rubber "B"	힌지 고무(소)	2	
J-5	CST-FD001100		Head Support Subber "A"	힌지 고무(중)	2	
	GP-052071-00	Option	Head Support Subber "A"(Full Submerged Type Table)	힌지 고무(중)(내림 테이블)	2	
J-6	CST-FF000400		Rubber Cushion For Hinge	힌지 고무(대)	2	
J-7	CST-BB002500		Head Hinge	힌지	2	
J-8	CAC-MA000500		Sewing Machine Cover	미싱커버(대)	1	
J-9	PTL-BA000100		Driver(Large)	드라이버(대)	1	
J-10	PTL-BA000200		Driver(Middle, Small)	드라이버(중, 소)	1	
J-11	CST-MF000100		Thread Stud Ass'y	실폐꽃이(조)	1Set	
J-12	CGA-GA000200		Needle Plate	침판	1	
J-13	CGA-GA002000		Needle Plate	침판	1	
J-14	CGA-GA003200		Needle Plate(AL-Type)	침판(박물용)	1	
J-15	CST-CR000500		Knee Base Rubber	무릎 올림봉 받침캡	1	
J-16	DPK-DC000300		Cap	오일팬 누유 방지 고무	1	
J-17	-		Nail	못	10	
J-18	CHK-HB000600		Bobbin	보빈	2	
J-19	-		Needle	바늘 A형	1	
J-20	-		Needle	바늘 B형	1	
J-21	CST-CR000100		Head Support Pole	미싱 받침대	1	
J-22	91-004C-1230		Cloth Guide	정규	1	
J-23	SC-0204-1230		Screw(9/64"n = 40)	홈볼이 바인딩 작은나사(9/64"n=40)	1	
J-24	DTC-AK000300		Magnet	자석	1	
J-25	60-101A-2350		Belt Cover Ass'y(Only For Trimming M/C)	벨트커버(조)-사절	1Set	
J-25-1	CMB-LA019600		Belt Cover(A)	벨트커버(A)	1	
J-25-2	CMB-LA019500		Belt Cover(B)	벨트커버(B)	1	
J-25-3	CMB-LA019700		Belt Cover(C)	벨트커버(C)	1	
J-25-4	CMB-LA019800		Belt Cover(D)	벨트커버(D)	1	
J-25-5	PSC-DD000100		Screw	목나사	2	
J-25-6	DSC-BF001200		Screw(11/64"n = 40)	가마잡이 나사(11/64"n = 40)	2	
J-25-7	DSC-BJ000200		Screw(11/64"n = 40)	홈볼이 둥근 작은나사(11/64"n=40)	6	
J-25-8	DSC-HB002500		Screw For Belt Cover	벨트커버 지지나사	2	
J-26	CLB-JG000300		Oil Return Tube	환류 파이프	1	

**NOTE:**

A=KM-235A  
B=KM-235B

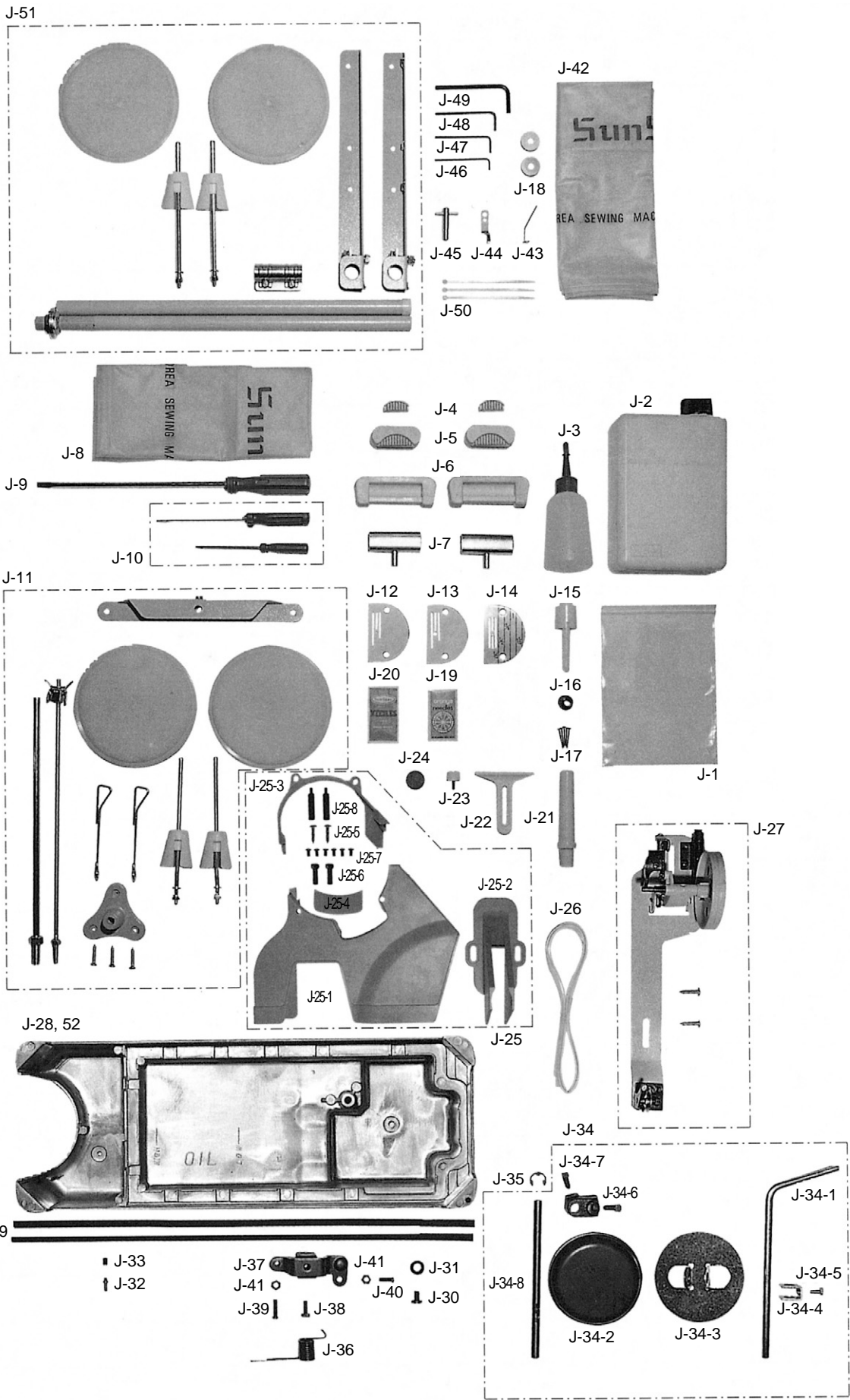

Ref. No.	Parts No.	Note	Name of Parts	품 명	Q'ty	Applied Period
J-27	AS-009197-00		Bobbin Winder Ass'y	실감기(조)	1	
J-28	CST-JA000800	A	Oil Pan	오일 팬	1	
J-29	CAC-MG000300		Oil Pan Gasket	오일 팬 가스켓	2	
J-30	DSC-BF006100		Screw(M8×1.25)	배유구멍 마개 나사(M8×1.25)	1	
J-31	CST-FB000200		Packing	배유 구멍마개 나사 오링	1	
J-32	CLB-JP002500		Oil Pan Nipple	오일 팬 니플	1	
J-33	DSC-CA003500		Screw(15/64"n=28)	피드캠 쥘나사(15/64"n=28)	1	
J-34	43-101A-1600		Knee Lifting Ass'y	무릎 올림(조)	1set	
J-34-1	CST-KC001300		Knee Lifter Shaft	무릎 받침축	1	
J-34-2	CST-FZ000100		Knee Lifter Pad	무릎 받침 고무	1	
J-34-3	CST-BJ000400		Knee Lifter Pad Insert Plate	무릎 받침 고무 잡이 판	1	
J-34-4	CST-CA000200		Holder	무릎 받침 고무 연결 링크	1	
J-34-5	DSC-AA002700		Set Screw	무릎 받침 연결 링크 쥘나사	1	
J-34-6	CST-CB000300		Knee Lifter Arm Joint Complete	무릎 받침 연결 크랭크	1	
J-34-7	DSC-CC000100		Screw(5/16"n=18)	무릎 받침 축 고정나사(5/16"n=18)	2	
J-34-8	CST-KC001200		Shaft	제어체 축	1	
J-35	PSR-AC000100		E-Ring(∅9)	제어체 축 링(E링∅9)	1	
J-36	DSP-AC005600		Spring	제어체 스프링	1	
J-37	CST-BB002900		Knee Lifting Controller	제어체	1	
J-38	DSC-AA000300		Screw(15/64"n=28)	포크 쥘나사	1	
J-39	DSC-BA002700		Screw(15/64"n=28)	제어체 운동조절 나사(중)(15/64"n=28)	1	
J-40	DSC-BA002800		Screw(15/64"n=28)	제어체 운동조절 나사(대)(15/64"n=28)	1	
J-41	DSN-AA000400		Nut(15/64"n=28)	수평운동 로드 단나사 너(15/64"n=28)	2	
J-42	CAC-MA000500		Sewing Machine Cover	미싱커버(대)	1	
J-43	CWP-BH001100		Wiper	와이퍼	1	
J-44	CTT-NB000500		Fixed Mes	고정 메스	1	
J-45	DTL-CC000100		Box Spanner	고정 메스 장력 조절용 스패너	1	
J-46	PTL-AB000100		Wrench(2mm)	렌치(2mm)	1	
J-47	PTL-AB000300		Wrench(2.5mm)	렌치(2.5mm)	1	
J-48	PTL-AB000500		Wrench(3mm)	렌치(3mm)	1	
J-49	PTL-AB000200		Wrench(5mm)	렌치(5mm)	1	
J-50	PTC-AG000100		Nylon Clip	나일론 클립	4	
J-51	CST-MF000100		Thread Stud Ass'y	실폐꽃이(조)	1Set	
J-52	CST-JA002500	B	Oil Pan	오일팬	1	

**NOTE:**

A=KM-235A  
B=KM-235B

## Program Unit Box & Automatic Presser Foot Lifter

### 프로그램 유닛 박스 및 자동 무릎 올림 관계

K-62

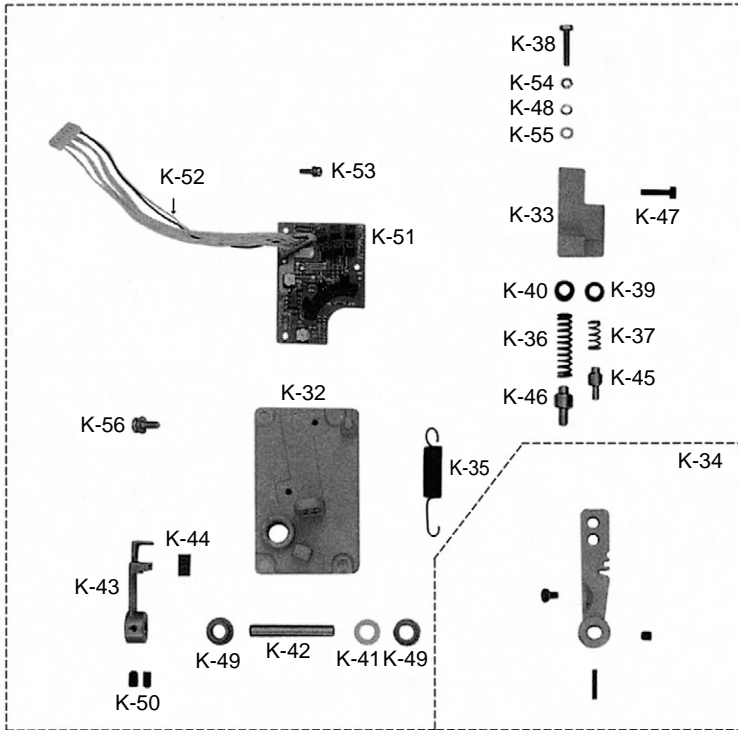

K-57

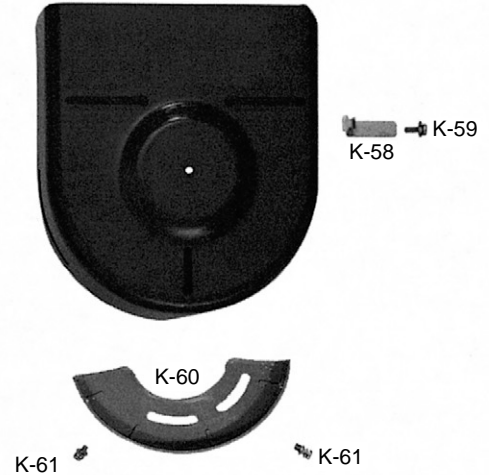

K-1

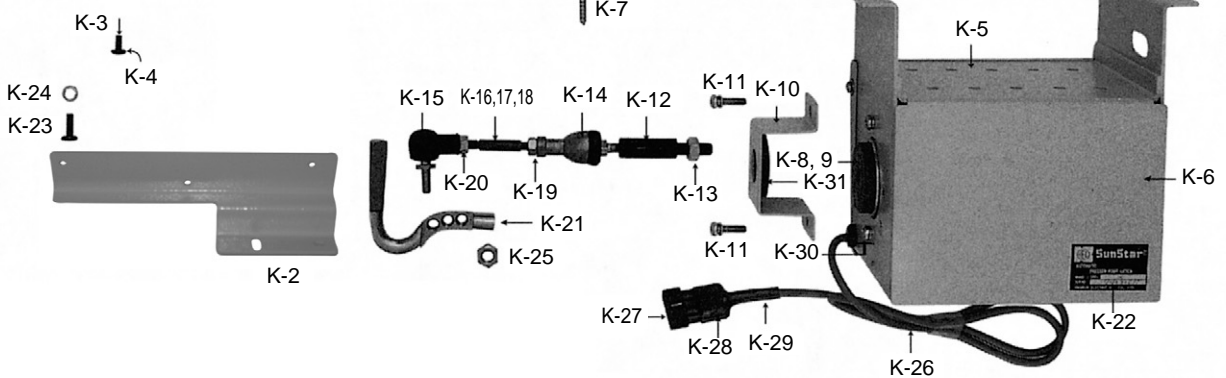
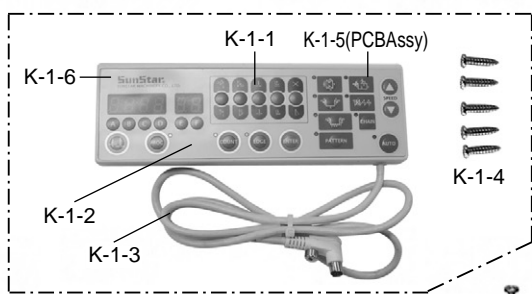

K-63

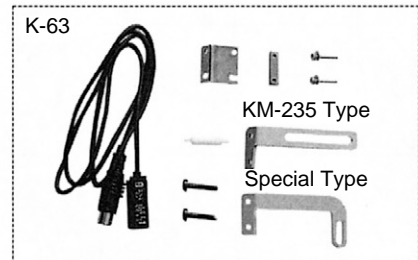

Ref. No.	Parts No.	Note	Name of Parts	품 명	Q'ty	Applied Period
K-1	EE-001523-00		S-5 P/U B/D Ass'y	S-5 P/U 보드 Ass'y	1Set	
K-1-1	GP-024743-00		Front cover	전면 커버	1	
K-1-2	GP-024747-00		Membrane Switch	멤브레인 스위치	1	
K-1-3	CA-000479-00		P/U Connector Cable(SE-013)	P/U 연결 케이블(SE-013)	1	
K-1-4	30-001M-SE55		Screw For P/U Box	M3*16 플랜지 볼이 고정나사	5	
K-1-5	BD-000255-03		P/U PCB Ass'y	P/U PCB Ass'y	1Set	
K-1-6	GP-024744-00		Rear cover	후면 커버	1	
K-2	GP-051355-00		Bracket For Program Unit Box(KM-235)	브라켓	1	
K-3	91-029S-1000		Screw For P/U Box	고정나사	1	
K-4	91-029S-1000		Screw For P/U Box(Special)	고정나사	1	
K-5	18-107B-9000		Auto Knee Lifter Solenoid Case	자동 무릎올림 솔레노이드 케이스	1	
K-6	18-018B-9000		Auto Knee Lifter Solenoid Cover	자동 무릎올림 솔레노이드 커버	1	
K-7	91-027B-3000		Screw For C-9 Bracket	고정나사	1	
K-8	-		Shaft(B) For Solenoid	축(A)	1	
K-9	-		Shaft(A) For Solenoid	축(B)	1	
K-10	18-109B-9000		Fixing Plate For Stroke	고정판	4	
K-11	01-134C-1701		Screw	고정나사	1	
K-12	18-011B-5607		Solenoid Shaft Connecting Rod.	연결로드	1	
K-13	18-019S-5607		Nut	너트	4	
K-14	18-020A-5607		Ball Joint(Right)	조인트(우)	1	
K-15	18-021A-5607		Ball Joint(Left)	조인트(좌)	1	
K-16	18-018B-5607		Middle Connecting Bar(KM-235)	중간 연결 바(KM-235)	1	
K-17	25-004A-3200		Middle Connecting Bar(Special)	중간 연결 바(Special)	1	
K-18	25-004A-5607		Middle Connecting Bar(KM-560-7)	중간 연결 바(KM-560-7)	1	
K-19	18-016S-5607		Nut(R )	너트(우)	1	
K-20	18-015S-5607		Nut(L)	너트(좌)	1	
K-21	25-006A-3200		Knee Lifting Shaft	무릎올림 축	1	
K-22	20-016C-6100		Sticker For Auto Knee Lifting Sol.	스티커	1	
K-23	91-030S-1000		Screw For P/U Box Bracket	고정나사	2	
K-24	01-039W-1701		Spring Washer For P/U Box Bracket	스프링 와셔	2	
K-25	18-016S-5607		Nut	너트	1	
K-26	12-015M-2350		Cable For Auto Knee Lifting Solenoid	케이블	1	
K-27	-		Connector Pin	연결핀	2	
K-28	17-016B-3000		Plug For Auto Knee Lifting Solenoid	플러그	1	

**NOTE:**

A=KM-235A  
B=KM-235B

## Program Unit Box & Automatic Presser Foot Lifter

### 프로그램 유닛 박스 및 자동 무릎 올림 관계

K-62

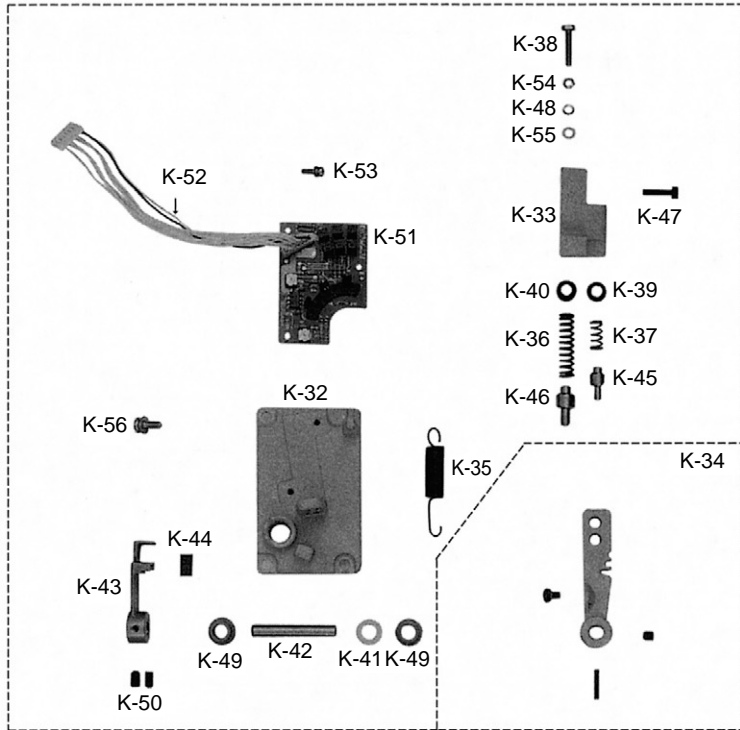

K-57



K-58 K-59



K-61 K-61

K-1

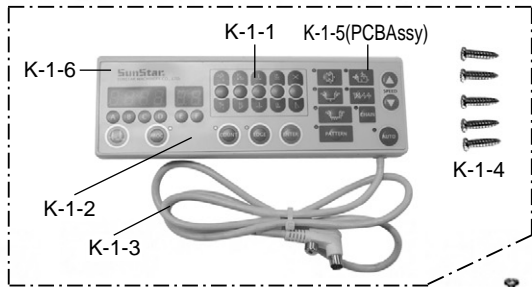

K-3 K-4 K-7

K-24 K-23



K-2

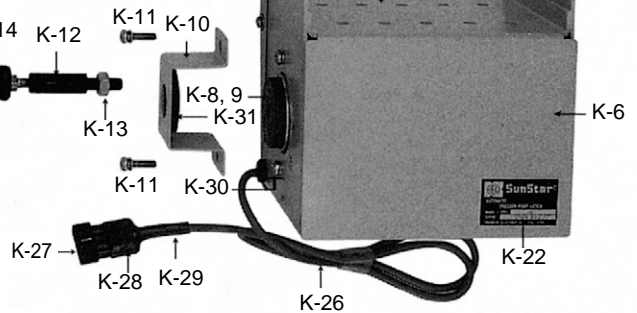
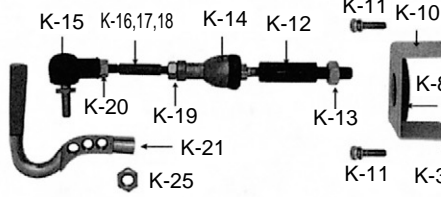

K-63

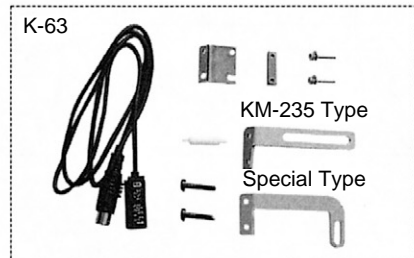

KM-235 Type

Special Type

Ref. No.	Parts No.	Note	Name of Parts	품명	Q'ty	Applied Period
K-29	08-014C-3701		Tube(C)	튜브(C)	1	
K-30	18-029C-5607		Guide Bushing For Cable	가이드 부싱	1	
K-31	18-023R-5607		Rubber Washer	고무와셔	1	
K-32	11-011A-SF55		Pedal Base	페달 베이스	1	
K-33	10-016A-SC53		Spring Housing	스프링 하우징	1	
K-34	10-107A-SC53		Pedal Control Lever(Ass'y)	페달 레버(조)	1Set	
K-35	10-018G-SC53		Tension Spring For Pedal	장력 스프링	1	
K-36	10-019G-SC53		Pressure Spring For Presser Foot	압력 스프링	1	
K-37	10-020G-SC53		Pressure Spring For Thread Trimming	압력 스프링	1	
K-38	10-021S-SC53		Pressure Control Screw For Thread Trimming	고정나사	1	
K-39	10-024P-SC53		Spring Guide(A)	스프링 가이드(A)	1	
K-40	10-025P-SC53		Spring Guide(B)	스프링 가이드(B)	1	
K-41	10-024W-SC53		Parallel Washer For Pedal Shaft	와셔	1	
K-42	ST-000287-00		Shaft For Pedal Control Lever	축	1	
K-43	10-026A-SC53		Pedal Magnet & Film Base	페달 자석 & 필름 베이스	1	
K-44	10-027C-SC53		Pedal Magnet	페달 자석	1	
K-45	10-029P-SC53		Stopper(A) For Pressure Spring	스토퍼(A)	1	
K-46	10-030P-SC53		Stopper(B) For Pressure Spring	스토퍼(B)	1	
K-47	10-031S-SC53		Screw For Spring Housing	고정나사	2	
K-48	10-031W-SC53		Parallel Washer	와셔	1	
K-49	11-012C-3701		Bushing For Pedal Control Lever Shaft	붓싱	2	
K-50	03-004S-SM55		Fixing Bolt For Pedal Magnet & Film Base	고정나사	2	
K-51	06-1000-SE55		Pedal P.C.B Ass'y	페달 P.C.B(조)	1Set	
K-52	12-009B-SE55		Connector for Pedal	컨넥터	1	
K-53	10-028S-SC53		Screw For Pedal P.C.B	고정나사	3	
K-54	10-010M-AT10		Fixing Nut	너트	1	
K-55	02028SW-9115		Fixing Spring Washer	스프링 와셔	1	
K-56	06-001M-SE55		Screw For Pedal Base	고정나사	4	
K-57	91-001A-3701		Belt Cover(B)	벨트 커버(B)	1	
K-58	91-004C-SA53		Belt Guide	벨트 가이드	1	
K-59	09-031S-3701		Screw For Belt Guide	고정나사	1	
K-60	91-101A-SA53		Belt Cover(A)	벨트 커버(A)	1	
K-61	07-027S-3701		Screw For Belt Cover(A)	고정나사	2	
K-62	06-0000-SE55		Pedal Unit Assembly	페달 유닛(조)	1Set	
K-63	EA-000023-00		Edge Sensor	센서	1Set	

**NOTE:**

A=KM-235A  
B=KM-235B

# INDEX

Parts No.	Name of Parts	Page	Ref.No.
-	Needle	9	B-42
-	Needle	9	B-43
-	Nail	31	J-17
-	Needle	31	J-19
-	Needle	31	J-20
-	Shaft(B) For Solenoid	35	K-8
-	Shaft(A) For Solenoid	35	K-9
-	Connector Pin	35	K-27
01-035P-1230	Machine Number Plate	7	A-29
01-039W-1701	Spring Washer For P/U Box Bracket	35	K-24
01-134C-1701	Screw	35	K-11
02028SW-9115	Fixing Spring Washer	37	K-55
03-004S-SM55	Fixing Bolt For Pedal Magnet & Film Base	37	K-50
06-0000-SE55	Pedal Unit Assembly	37	K-62
06-001M-SE55	Screw For Pedal Base	37	K-56
06-1000-SE55	Pedal P.C.B Ass'y	37	K-51
07-027S-3701	Screw For Belt Cover(A)	37	K-61
08-014C-3701	Tube(C)	37	K-29
09-031S-3701	Screw For Belt Guide	37	K-59
10-010M-AT10	Fixing Nut	37	K-54
10-016A-SC53	Spring Housing	37	K-33
10-018G-SC53	Tension Spring For Pedal	37	K-35
10-019G-SC53	Pressure Spring For Presser Foot	37	K-36
10-020G-SC53	Pressure Spring For Thread Trimming	37	K-37
10-021S-SC53	Pressure Control Screw For Thread Trimming	37	K-38
10-024P-SC53	Spring Guide(A)	37	K-39
10-024W-SC53	Parallel Washer For Pedal Shaft	37	K-41
10-025P-SC53	Spring Guide(B)	37	K-40
10-026A-SC53	Pedal Magnet & Film Base	37	K-43
10-027C-SC53	Pedal Magnet	37	K-44
10-028S-SC53	Screw For Pedal P.C.B	37	K-53
10-029P-SC53	Stopper(A) For Pressure Spring	37	K-45
10-030P-SC53	Stopper(B) For Pressure Spring	37	K-46
10-031S-SC53	Screw For Spring Housing	37	K-47
10-031W-SC53	Parallel Washer	37	K-48
10-107A-SC53	Pedal Control Lever(Ass'y)	37	K-34
11-011A-SF55	Pedal Base	37	K-32
11-012C-3701	Bushing For Pedal Control Lever Shaft	37	K-49
11-015A-2700	Wiper Solenoid Assembly	27	H-15
11-020A-2500	Magnetic Holder	9	B-45-1
11-021S-2500	Screw For Magnetic Holder	9	B-45-3
11-022W-2500	Washer For Magnetic Holder	9	B-45-2
12-004A-2700	Reverse Selection Switch	26	G-19
12-006S-2700	Support Screw	26	G-9
12-009B-SE55	Connector for Pedal	37	K-52
12-009C-2700	Reverse Button Switch	26	G-16
12-009C-2700	Reverse Selection Switch Ass'y	26	G-21
12-015M-2350	Cable For Auto Knee Lifting Solenoid	35	K-26
12-016M-2350	Earth Line	7	A-50
12-104A-2700	Reverse Selection Switch Ass'y	26	G-22
13-0000-SE55	Synchronizer Ass'y (Servo)	9	B-45-4
13-2000-SE55	Synchronizer Ass'y	9	B-45
17-016B-3000	Plug For Auto Knee Lifting Solenoid	35	K-28
18-011B-5607	Solenoid Shaft Connecting Rod.	35	K-12
18-015S-5607	Nut(L)	35	K-20
18-016S-5607	Nut(R)	35	K-19
18-016S-5607	Nut	35	K-25
18-018B-5607	Middle Connecting Bar(KM-235)	35	K-16
18-018B-9000	Auto Knee Lifter Solenoid Cover	35	K-6
18-019S-5607	Nut	35	K-13
18-020A-5607	Ball Joint(Right)	35	K-14

Parts No.	Name of Parts	Page	Ref.No.
18-021A-5607	Ball Joint(Left)	35	K-15
18-023R-5607	Rubber Washer	37	K-31
18-029C-5607	Guide Bushing For Cable	37	K-30
18-107B-9000	Auto Knee Lifter Solenoid Case	35	K-5
18-109B-9000	Fixing Plate For Stroke	35	K-10
20-016C-6100	Sticker For Auto Knee Lifting Sol.	35	K-22
25-004A-3200	Middle Connecting Bar(Special)	35	K-17
25-004A-5607	Middle Connecting Bar(KM-560-7)	35	K-18
25-006A-3200	Knee Lifting Shaft	35	K-21
30-001M-SE55	Screw For P/U Box	35	K-1-4
43-101A-1600	Knee Lifting Ass'y	33	J-34
44-120S-1230	Screw(11/64"n = 40)	29	I-1-14
60-101A-2350	Belt Cover Ass'y(Only For Trimming M/C)	31	J-25
91-001A-3701	Belt Cover(B)	37	K-57
91-004C-1230	Cloth Guide	31	J-22
91-004C-SA53	Belt Guide	37	K-58
91-027B-3000	Screw For C-9 Bracket	35	K-7
91-029S-1000	Screw For P/U Box	35	K-3
91-029S-1000	Screw For P/U Box(Special)	35	K-4
91-030S-1000	Screw For P/U Box Bracket	35	K-23
91-101A-SA53	Belt Cover(A)	37	K-60
AAB-SM008301	Arm. Bed Assembly	5	A-1
AFA-PS000100	Dial Shaft Locker Ass'y	17	D-95
AGA-PS002200	Hinged Foot Complete	19	E-11
ALB-PS002200	Oil Pump Ass'y	29	I-1
ALB-PS002300	Main Shaft Oil Pipe Ass'y	29	I-6
AMB-PS001400	Slide Plate Ass'y	7	A-32
ARB-PS000700	Reverse Button Ass'y	26	G-1
AS-000042-00	Wire Rope	21	E-46-1
AS-000042-00	Cable	21	E-46-2
AS-009197-00	Bobbin Winder Ass'y	33	J-27
AS-016315-01	Take-Up Lever Complete	9	B-29
AS-016316-01	Take-Up Lever Complete	9	B-28
ATA-PS001201	Supplementary Tension Ass'y	5	A-17
ATA-PS001303	Tension Adjusting Apparatus Ass'y	5	A-14
ATR-PS000200	Thread Tension Release Plate	19	E-26
ATR-PS000300	Tension Release Cable	21	E-46
BD-000255-03	P/U PCB Ass'y	35	K-1-5
CA-000479-00	P/U Connector Cable(SE-013)	35	K-1-3
CAB-AA0004600	Arm	5	A-1-1
CAB-AB003904	Bed	5	A-1-2
CAB-AB003908	Bed	5	A-1-2
CAC-JB000100	Oil Tank	31	J-3
CAC-MA000500	Sewing Machine Cover	31	J-8
CAC-MA000500	Sewing Machine Cover	33	J-42
CAC-MD000300	Oil	31	J-2
CAC-MG000300	Oil Pan Gasket	33	J-29
CAC-MH000100	Accessory Box	31	J-1
CFA-BB001300	Stopper	17	D-108
CFA-BM000100	Dial Shaft Stopper	17	D-95-3
CFA-BN000100	Dial Shaft Holder	17	D-95-1
CFA-BN000200	Dial Shaft Holder Body	17	D-95-2
CFA-CA000300	Feed Regulator Link	13	D-28
CFA-CB0003300	Feed Regulator Arm	17	D-96
CFA-CL000200	Roller	17	D-98
CFA-CM000300	Dial Shaft Stopper Handle	17	D-95-4
CFA-CM001300	Reverse Feed Control Lever	17	D-105
CFA-CQ001100	Feed Regulating Dial-Insert Type	17	D-92
CFA-CQ001300	Feed Regulating Dial-Insert Type	17	D-93
CFA-D F000101	Feed Regulating	17	D-83
CFA-K F000100	Shaft	17	D-102

Parts No.	Name of Parts	Page	Ref.No.
CFA-KF000201	Shaft	17	D-85
CFA-KJ001100	Feed Regulator Dial Shaft	17	D-88
CGA-GA000200	Needle Plate	7	A-33
CGA-GA000200	Needle Plate	31	J-12
CGA-GA002000	Needle Plate	7	A-34
CGA-GA002000	Needle Plate	31	J-13
CGA-GA003200	Needle Plate (AL-Type)	7	A-35
CGA-GA003200	Needle Plate(AL-Type)	31	J-14
CGA-GB000501	Feed Dog	13	D-16
CGA-GB001500	Feed Dog	13	D-17
CGA-GC000701	Hinged Foot Complete	19	E-10
CHK-HA000700	Rotary Hook Ass'y	11	C-24
CHK-HA000900	Rotary Hook Ass'y	11	C-25
CHK-HB000600	Bobbin (A1)	11	C-26
CHK-HB000600	Bobbin	31	J-18
CHK-HC000700	Bobbin Case Ass'y	11	C-27
CHK-HH000400	Hook Retainer	11	C-28
CLB-BB001700	Oil Pump Bracket	29	I-1-17
CLB-BG002100	Magnet Holder	29	I-1-13
CLB-BG002200	Holder	29	I-9
CLB-BG002300	Retainer Plate For Oil Wick	13	D-10
CLB-BH000300	Retainer For Oil Tube	19	E-4
CLB-BJ000400	Oil Shield	29	I-11
CLB-BR000100	Impeller	29	I-1-6
CLB-CN000200	Piston	29	I-1-7
CLB-FZ000100	Rubber Flange	13	D-7
CLB-JC000200	Oil Pump Body	29	I-1-1
CLB-JF002200	Lower Shaft Oil Pipe	29	I-8
CLB-JG000300	Oil Return Tube	29	I-7
CLB-JG000300	Oil Return Tube	31	J-26
CLB-JJ001200	Oil Gauge Window	7	A-22
CLB-JL001600	Felt	9	B-3
CLB-JL002400	Felt	11	C-2
CLB-JM000400	Oil Pump Cap	29	I-1-12
CLB-JP000501	Nipple For Oil Return Pipe	29	I-1-4
CLB-JP000601	Nipple For Lower Shaft	29	I-1-5
CLB-JP002500	Oil Pan Nipple	33	J-32
CLB-LB000100	Oil Pump Cover	29	I-1-11
CLF-CA000200	Feed Connecting Link(A)	13	D-25
CLF-CA000300	Feed Connecting Link(B)	13	D-26
CLF-CB000700	Feed Rocker	13	D-8
CLF-CB000800	Crank(Rear)	13	D-21
CLF-CD000400	Sliding Block and Shaft	13	D-20
CLF-CR000300	Feed Bar	13	D-12
CLF-KF000100	Feed Lifting Shaft	13	D-36
CLF-KF000200	Feed Roker Shaft	13	D-1
CLF-KH000100	Feed Bar Shaft	13	D-13
CLS-KC002600	Lower Shaft	11	C-1
CMB-BB004500	Bed Leg Right	7	A-38
CMB-BJ002400	Gauge Plate	7	A-52
CMB-FC005800	Gasket	7	A-21
CMB-FC005900	Gasket	5	A-3
CMB-HK000500	Thread Guide For Arm	5	A-11
CMB-HK001900	Thread Guide Left	5	A-6
CMB-HK002000	Guide Bar For Thread	7	A-19
CMB-LA018000	Cover For Take Up Lever	5	A-9
CMB-LA018100	Top Cover	7	A-20
CMB-LA018200	Face Plate	5	A-2
CMB-LA019500	Belt Cover(B)	31	J-25-2
CMB-LA019600	Belt Cover(A)	31	J-25-1
CMB-LA019700	Belt Cover(C)	31	J-25-3



# INDEX

Parts No.	Name of Parts	Page	Ref.No.
CMB-LA019800	Belt Cover(D)	31	J-25-4
CMB-LB008000	Cable Cover	7	A-42
CMB-LD003200	Model Mark	7	A-27
CMB-LD003500	Model Mark	7	A-28
CNB-CD000201	Sliding Block	9	B-33
CNB-HK002100	Thread Guide	9	B-40
CNB-HK002200	Thread Guide "A"	9	B-39
CNB-KA002600	Needle Bar	9	B-34
CNB-KA002700	Needle Bar	9	B-35
CPB-BF000400	Holder	19	E-13
CPB-BH000600	Safety Guide	21	E-59
CPB-CM000300	Presser Bar Lifter Lever	19	E-17
CPB-DF000700	Cam Shaft	19	E-19
CPB-HK000101	Thread Guide For Frame	19	E-14
CPB-KB000100	Presser Bar	19	E-1
CPB-KC000300	Presser Regulator Bar	19	E-5
CPM-BH000900	Connecting Rod	21	E-33
CPM-CA001700	Knee Lifting Link	21	E-36
CPM-CM002300	Knee Lifter Plate	19	E-24
CPM-CR000901	Knee Lifting Rod	21	E-43
CRB-BJ000500	Pushing Plate	26	G-17
CRB-BK000300	Reverse Selection Button	26	G-6
CRB-FD000200	Insulated Rubber(B) For Switch	26	G-13
CRB-FD000300	Insulated Rubber (A) For Switch	26	G-14
CRB-KC000200	Shaft	26	G-7
CRB-LA000100	Cover	26	G-15
CRB-LC000400	Button Case	26	G-12
CST-BB002500	Head Hinge	31	J-7
CST-BB002900	Knee Lifting Controller	33	J-37
CST-BJ000400	Knee Lifter Pad Insert Plate	33	J-34-3
CST-CA000200	Holder	33	J-34-4
CST-CB000300	Knee Lifter Arm Joint Complete	33	J-34-6
CST-CR000100	Head Support Pole	31	J-21
CST-CR000500	Knee Base Rubber	31	J-15
CST-FB000200	Packing	33	J-31
CST-FD001100	Head Support Rubber "A"	31	J-5
CST-FD001200	Head Support Rubber "B"	31	J-4
CST-FF000400	Rubber Cushion For Hinge	31	J-6
CST-FZ000100	Knee Lifter Pad	33	J-34-2
CST-JA000800	Oil Pan	33	J-28
CST-JA002500	Oil Pan	33	J-52
CST-KC001200	Shaft	33	J-34-8
CST-KC001300	Knee Lifter Shaft	33	J-34-1
CST-MF000100	Thread Stud Ass'y	31	J-11
CST-MF000100	Thread Stud Ass'y	33	J-51
CTA-BA000200	Tension Barrel	5	A-14-1
CTA-BJ000100	Tension Release Washer	5	A-14-7
CTA-HK000200	Guide Plate	5	A-17-1
CTA-HL000100	Tension Disk	5	A-14-6
CTA-HL000300	Tension Disk	5	A-17-3
CTA-HM000500	Tension Stud	5	A-14-4
CTA-HM000601	Shaft	5	A-17-2
CTR-BB001100	Stopper	19	E-30
CTR-BQ000200	Pipe For Thread Release Lever	21	E-54
CTR-CM001200	Operating Lever For Thread Release	21	E-50
CTR-CM001300	Cam Driving Lever	21	E-51
CTR-KC000500	Shaft	19	E-22
CTT-BB002900	Stopper	25	F-36
CTT-BB003100	Solenoid Base	25	F-42
CTT-BF000200	Holder	25	F-50
CTT-BF001700	Holder	23	F-12

Parts No.	Name of Parts	Page	Ref.No.
CTT-BH000101	Bobbin Presser Bar	25	F-48
CTT-BH000600	Lever	25	F-49
CTT-BJ001100	Thread Detachable Plate	23	F-5
CTT-BN000500	Spring Guide	23	F-26
CTT-CA001700	Connecting Link	23	F-14
CTT-CM002900	Thread Trimmer Lever	23	F-18
CTT-CM003000	Clutch Lever	25	F-44
CTT-CM003100	Stopper Lever	23	F-28
CTT-DF000501	Reversal Cam	23	F-20
CTT-FD000100	Stopper Rubber	25	F-55
CTT-FD000300	Cushion Rubber (A)	25	F-39
CTT-FZ000100	Cushion Rubber	25	F-40
CTT-KF000700	Thread Trimmer Shaft	23	F-23
CTT-NA000600	Rotary Mes	23	F-7
CTT-NA001000	Rotary Mes	23	F-8
CTT-NB000500	Fixed Mes	33	J-44
CTT-NB000901	Fixed Mes	23	F-1
CUR-KC000100	Upright Shaft	11	C-15
CUS-CH000101	Adjusting Valve For Lubrication	9	B-5
CUS-DA002600	Counterweight	9	B-23
CUS-DA002700	Counterweight	9	B-24
CUS-FA000100	Rubber	9	B-2
CUS-KC002601	Main Shaft	9	B-1
CWP-BA000100	Crank Rotary Regulator Plate	27	H-11
CWP-BB001500	Solenoid Bracket	27	H-17
CWP-BF000500	Holder	27	H-4
CWP-BH001100	Wiper	27	H-1
CWP-BH001100	Wiper	33	J-43
CWP-BJ001400	Crank Rotary Plate	27	H-8
CWP-CA001900	Connecting Rod	27	H-14
CWP-CB000800	Wiper Crank	27	H-6
CWP-KF000100	Wiper Rotary Shaft	27	H-2
CWP-LA000500	Cover	27	H-22
D-41	Screw(15/64"n = 28)	15	D-41
D-42	Feed Lifting Bell Arm	15	D-42
D-43	Screw(3/16"n = 28)	15	D-43
D-44	Screw(3/16"n = 32)	15	D-44
D-45	Rear Crank	15	D-45
D-46	Rear Crank	15	D-46
D-47	Screw(3/16"n = 28)	15	D-47
D-48	Hinge Pin	15	D-48
D-49	Screw(11/64"n = 40)	15	D-49
D-50	Oil Wick	15	D-50
D-51	Holder For Oil Wick	15	D-51
D-52	Reverse Feed Solenoid Ass'y	15	D-52
D-53	Stud Screw For Connecting Rod	15	D-53
D-54	Bracket For Reverse Feed Solenoid	15	D-54
D-55	Screw(M5×0.8)	15	D-55
D-56	Spring Washer For Bracket	15	D-56
D-57	Screw(M6)	15	D-57
D-58	Reverse Feed Solenoid Crank	15	D-58
D-59	Stud Screw For Solenoid Crank	15	D-59
D-60	Hinge Nut For Connecting Rod	15	D-60
D-61	Reverse Solenoid Connecting Rod	15	D-61
D-62	Tube	15	D-62
D-63	Plug	15	D-63
D-64	Hinge Pin For Connecting Rod	15	D-64
D-65	Feed Rocker Shaft Connecting Rod	15	D-65
D-66	Screw(11/64"n = 40)	15	D-66
D-67	Feed Cam(A)	15	D-67
D-68	Feed Cam(B)	15	D-68

Parts No.	Name of Parts	Page	Ref.No.
D-69	Screw(1/4"n = 40)	15	D-69
D-70	Stopper C-Ring	15	D-70
D-71	Crank Rod Complete	15	D-71
D-72	Feed Cam(C)	15	D-72
D-73	Screw(1/4"n = 40)	15	D-73
D-74	Connecting Rod For Feed Regulator	15	D-74
D-75	B/T Spring Holder	15	D-75
D-76	Screw(9/64"n = 40)	15	D-76
D-77	Reverse Feed Spring	15	D-77
D-78	Holder For Reverse Feed Spring	15	D-78
D-79	E-Ring	15	D-79
D-80	Feed Adjusting Shaft	15	D-80
DBS-DA003400	Needle Bar Upper Bushing	9	B-36
DBS-DA003700	Vertical Shaft Upper Bushing	11	C-16
DBS-DA003801	Upright Shaft Lower Bushing	11	C-18
DBS-DA004100	Lower Shaft Rear Bushing	11	C-11
DBS-DA006700	Bushing(Front)	13	D-2
DBS-DA006800	Rear Bushing	13	D-5
DBS-DA006800	Rear Bushing	13	D-40
DBS-DA007100	Front Bushing	13	D-37
DBS-DA018200	Bushing	19	E-2
DBS-DA020000	Bushing	23	F-24
DBS-DA024900	Needle Bar Lower Bushing	9	B-38
DBS-DA025800	Main Shaft Center Bushing	9	B-11
DBS-DA025900	Lower Shaft Bushing(Front)	11	C-4
DBS-DB001101	Main Shaft Rear Bushing	9	B-17
DBS-DB007600	Main Shaft Front Bushing	9	B-9
DBS-DB007700	Lower Shaft Bushing(Center)	11	C-8
DBS-DB008100	Guide Bushing	26	G-4
DCL-AA000100	Main Shaft Collar	9	B-13
DCL-AA001500	Collar(B)	11	C-9
DCL-AA001500	Collar For Impeller Shaft	29	I-1-15
DCL-AA002600	Collar	29	I-4
DCL-AA002800	Collar	17	D-81
DCL-AA008200	Collar	21	E-52
DCL-BB002500	Collar	25	F-30
DGR-AA003001	Thread Trimmer Gear Assembly	23	F-21
DGR-AA003101	Thread Trimmer Gear "B"	25	F-35
DGR-AD000100	Main Shaft Gear	9	B-15
DGR-AD000200	Upright Shaft Upper Gear	11	C-20
DGR-AD000300	Upright Shaft Lower Gear	11	C-22
DGR-AD000400	Lower Shaft Gear	11	C-13
DPK-CA000100	Robber Plug	7	A-26
DPK-CB000200	Rubber Plug	5	A-5
DPK-CB000200	Robber Plug(Large)	7	A-25
DPK-CB000200	Rubber Plug	7	A-51
DPK-CB000400	Rubber Cap	9	B-44
DPK-CB000900	Face Plate Rubber Cap(L)	5	A-4
DPK-CB002500	Rubber Cap	13	D-4
DPK-CB002500	Rubber Cap	13	D-39
DPK-CB002900	Robber Plug(Small)	7	A-24
DPK-CC0001000	Rubber Plug For Cable	7	A-31
DPK-CZ000200	Ratchet	5	A-14-9
DPK-CZ000200	Packing	5	A-15
DPK-CZ000600	Rubber Cap	19	E-3
DPK-CZ000900	Oil Protection Rubber	9	B-30
DPK-DC000300	Cap	31	J-16
DPL-AA000201	Pulley	9	B-20
DPN-AA000100	Pin(A)	13	D-23
DPN-AA003800	Tension Release Pin	5	A-14-2
DPN-AA003900	Pin(B)	13	D-27

# INDEX

Parts No.	Name of Parts	Page	Ref.No.
DPN-AA004000	Pin(C )	13	D-32
DPN-AA004100	Hinge Pin	13	D-34
DPN-AA014100	Dial Pin	17	D-90
DPN-AA014200	Hinge Pin	27	H-9
DPN-AA014500	Tension Release Pin	5	A-13
DPN-AD009200	Collar Shaft	25	F-31
DPN-BC001000	Hinge Pin(A)	13	D-31
DPN-BC001100	Hinge Pin(B)	13	D-29
DPN-BC003900	Pin	17	D-97
DPSP-AA010800	Presser Regulation Spring	19	E-7
DSC-AA000300	Screw(15/64"n=28)	33	J-38
DSC-AA001000	Screw(3/16"n=28)	13	D-22
DSC-AA001300	Screw	5	A-1-4
DSC-AA002700	Set Screw	33	J-34-5
DSC-AA003000	Screw(3/16"n=32)	25	F-37
DSC-AA003200	Screw	5	A-1-3
DSC-AA003300	Screw(9/64"n=40)	21	E-32
DSC-AC002200	Screw(1/4"n=40)	25	F-33
DSC-AZ000300	Screw	5	A-1-5
DSC-BA000100	Screw(9/64"n=40)	5	A-7
DSC-BA000100	Screw(9/64"n=40)	5	A-12
DSC-BA000100	Screw(9/64"n=40)	27	H-23
DSC-BA000200	Screw(9/64"n=40)	19	E-12
DSC-BA000300	Screw(11/64"n=40)	29	I-12
DSC-BA000400	Screw(3/16"n=28)	17	D-100
DSC-BA000700	Screw(3/16"n=32)	21	E-58
DSC-BA000700	Screw(3/16"n=32)	25	F-43
DSC-BA000700	Screw(3/16"n=32)	27	H-13
DSC-BA000900	Screw(9/64"n=40)	7	A-45
DSC-BA000900	Screw(9/64"n=40)	7	A-47
DSC-BA000900	Screw(9/64"n=40)	7	A-49
DSC-BA001400	Screw(3/16"n=32)	17	D-106
DSC-BA002700	Screw(15/64"n=28)	33	J-39
DSC-BA002800	Screw(15/64"n=28)	33	J-40
DSC-BB001400	Screw(11/64"n=40)	23	F-9
DSC-BB002000	Screw(9/64"n=40)	23	F-2
DSC-BC000100	Screw(11/64"n=40)	7	A-36
DSC-BC000100	Screw for Needle Plate	7	A-53
DSC-BF000100	Screw(1/8"n=44)	9	B-41
DSC-BF000100	Screw(1/8"n=44)	25	F-51
DSC-BF000400	Screw(15/64"n=28)	13	D-15
DSC-BF000600	Screw(3/16"n=28)	29	I-2
DSC-BF000700	Screw(15/64"n=28)	23	F-19
DSC-BF000800	Screw(15/64"n=40)	9	B-21
DSC-BF001000	Screw(11/64"n=40)	17	D-84
DSC-BF001200	Screw(11/64"n=40)	19	E-15
DSC-BF001200	Screw(11/64"n=40)	31	J-25-6
DSC-BF001800	Screw(1/8"n=44)	13	D-19
DSC-BF001800	Screw(1/8"n=44)	27	H-3
DSC-BF001900	Screw(3/16"n=28)	17	D-94
DSC-BF002600	Screw(3/16"n=32)	13	D-9
DSC-BF003100	Screw(11/64"n=40)	5	A-10
DSC-BF003100	Screw(11/64"n=40)	11	C-30
DSC-BF003100	Screw(11/64"n=40)	17	D-101
DSC-BF003100	Screw(11/64"n=40)	27	H-5
DSC-BF003600	Screw(11/64"n=40)	13	D-3
DSC-BF003600	Screw(11/64"n=40)	13	D-33
DSC-BF003600	Screw(11/64"n=40)	13	D-35
DSC-BF003600	Screw(11/64"n=40)	27	H-21
DSC-BF003600	Screw(11/64"n=40)	29	I-10
DSC-BF003700	Screw(9/32"n=28)	9	B-27

Parts No.	Name of Parts	Page	Ref.No.
DSC-BF004000	Screw(3/16"n=32)	11	C-7
DSC-BF006100	Screw(M8×1.25)	33	J-30
DSC-BF006200	Screw(1/8"n=40)	23	F-3
DSC-BF006300	Screw(11/64"n=40)	13	D-24
DSC-BF007000	Set Screw	11	C-3
DSC-BF007400	Pin Screw	29	I-1-9
DSC-BF007700	Screw(1/8"n=44)	13	D-11
DSC-BG000200	Screw(5/16"n=28)	9	B-22
DSC-BJ000200	Screw(11/64"n=40)	31	J-25-7
DSC-BJ000300	Screw(11/64"n=40)	19	E-18
DSC-BJ000300	Screw(9/64"n=40)	29	I-1-3
DSC-BJ000400	Screw(11/64"n=40)	5	A-8
DSC-BJ001400	Screw(9/64"n=40)	19	E-16
DSC-BJ002400	Screw(3/16"n=32)	17	D-107
DSC-BJ003500	Screw(11/64"n=40)	7	A-43
DSC-BJ003500	Screw(11/64"n=40)	17	D-109
DSC-BJ003500	Screw(11/64"n=40)	23	F-6
DSC-BJ005700	Screw(M2×0.4)	26	G-20
DSC-BJ005800	Screw(1/8"n=44)	26	G-18
DSC-BJ005900	Screw For Top Cover	7	A-23
DSC-CA000100	Screw(15/64"n=28)	5	A-16
DSC-CA000100	Screw(15/64"n=28)	9	B-18
DSC-CA000100	Screw(15/34"n=28)	11	C-5
DSC-CA000100	Screw(15/64"n=28)	13	D-6
DSC-CA000100	Screw(15/64"n=28)	13	D-38
DSC-CA000200	Set Screw	5	A-14-5
DSC-CA000400	Screw(11/64"n=40)	29	I-1-16
DSC-CA000400	Screw(11/64"n=40)	29	I-5
DSC-CA000500	Screw(1/4"n=40)	9	B-14
DSC-CA000500	Screw(1/4"n=40)	9	B-16
DSC-CA000500	Screw(1/4"n=40)	9	B-25
DSC-CA000500	Screw(1/4"n=40)	11	C-14
DSC-CA000500	Screw(1/4"n=40)	17	D-82
DSC-CA000800	Screw(15/64"n=28)	9	B-10
DSC-CA000800	Screw(15/64"n=28)	9	B-12
DSC-CA000800	Screw(15/64"n=28)	9	B-31
DSC-CA000800	Screw(15/64"n=28)	11	C-12
DSC-CA000800	Screw(15/64"n=28)	11	C-17
DSC-CA000800	Screw(15/64"n=28)	11	C-19
DSC-CA000800	Screw(15/64"n=28)	17	D-87
DSC-CA000800	Screw(15/64"n=28)	23	F-25
DSC-CA001100	Screw(1/4"n=40)	9	B-26
DSC-CA001100	Screw(1/4"n=40)	13	D-30
DSC-CA001500	Screw(15/64"n=28)	25	F-56
DSC-CA001700	Screw(15/64"n=28)	9	B-37
DSC-CA001900	Screw(1/4"n=40)	11	C-21
DSC-CA001900	Screw(1/4"n=40)	11	C-23
DSC-CA003500	Screw(15/64"n=28)	33	J-33
DSC-CB000300	Screw(11/64"n=40)	7	A-18
DSC-CB000300	Screw(11/64"n=40)	11	C-10
DSC-CB000300	Screw(11/64"n=40)	19	E-23
DSC-CB000500	Screw(15/64"n=28)	23	F-22
DSC-CB000700	Screw(M5)	21	E-53
DSC-CC000100	Screw(5/16"n=18)	33	J-34-7
DSC-FA018800	Hinge Screw	21	E-44
DSC-FA019000	Pivot Screw	25	F-47
DSC-FA019100	Hinge Screw	27	H-12
DSC-FA019300	Pivot Screw	23	F-17
DSC-FA019400	Pivot Screw	23	F-15
DSC-FF002300	Hinge Screw	21	E-37
DSC-FH000900	Hinge Screw	21	E-40

Parts No.	Name of Parts	Page	Ref.No.
DSC-HA000100	Screw(9/16"n=20)	19	E-8
DSC-HB002500	Screw For Belt Cover	31	J-25-8
DSC-HC000300	Bed Leg Front	7	A-37
DSC-HC000400	Bed Leg Rear	25	F-52
DSC-HD000600	Adjusting Screw	17	D-111
DSC-HZ001100	Connecting Bolt	21	E-47
DSD-AA003200	Trimmer Solenoid Assembly	25	F-41
DSN-AA000100	Nut	7	A-19-1
DSN-AA000400	Nut(15/64"n=28)	33	J-41
DSN-AA000600	Nut(3/16"n=32)	21	E-39
DSN-AA000600	Nut(3/16"n=32)	21	E-45
DSN-AA000900	Nut(11/64"n=40)	17	D-112
DSN-AA000900	Nut(11/64"n=40)	23	F-16
DSN-AA001700	Nut(1/8"n=40)	23	F-4
DSN-AA002400	Nut(A)	21	E-48
DSN-AA003800	Nut	26	G-3
DSN-AA003900	Nut	26	G-10
DSN-CC000100	Presser Adjusting Nut	19	E-9
DSN-CD000100	Cap	5	A-14-10
DSN-CD000400	Nut	7	A-17-5
DSP-AA001600	Spring	11	C-6
DSP-AA002700	Piston Spring	29	I-1-8
DSP-AA002800	Feed Regulator Dial Spring	17	D-91
DSP-AA005200	Spring	17	D-99
DSP-AA010300	Presser Regulation Spring	19	E-6
DSP-AA010400	Spring	25	F-34
DSP-AA010500	Spring	26	G-8
DSP-AA010600	Solenoid Tension Spring	27	H-16
DSP-AB003500	Spring	17	D-110
DSP-AC001700	Spring	25	F-53
DSP-AC002300	Spring Joint	29	I-3
DSP-AC005600	Spring	33	J-36
DSP-AC005800	Spring	19	E-27
DSP-AC006400	Spring	23	F-27
DSP-AC006500	Spring	25	F-46
DSP-BA000900	Spring	5	A-17-4
DSP-BA001000	Tension Spring	5	A-14-8A
DSP-BA002300	Tension Spring	5	A-14-8B
DSP-BB000200	Check Spring	5	A-14-3
DTC-AH000100	Cable Holder	7	A-48
DTC-AH001200	Cable Clip(A)	21	E-57
DTC-AK000300	Magnet	31	J-24
DTL-CC000100	Box Spanner	33	J-45
DWS-AA000500	Washer	21	E-31
DWS-AA000500	Washer	21	E-60
DWS-AA000600	Washer	25	F-38
DWS-AA000600	Washer	25	F-45
DWS-AA001500	Washer	13	D-14
DWS-AA002700	Thrust Washer	9	B-32
DWS-AA003800	Felt Washer	19	E-20
DWS-AA003800	Washer	19	E-21
DWS-AA005100	Washer	23	F-11
DWS-AA016700	Flat Washer	21	E-55
DWS-CA000100	Spring Washer	11	C-29
DWS-CB000200	Corrugated Washer	17	D-104
EA-000023-00	Edge Sensor	37	K-63
EE-001523-00	S-5 P/U B/D Ass'y	35	K-1
GP-019000-00	Feed Dog(AL-Type)	13	D-18
GP-024743-00	Front cover	35	K-1-1
GP-024744-00	Rear cover	35	K-1-6
GP-024747-00	Membrane Switch	35	K-1-2



---

**MEMO**





# MEMO

A large, empty rectangular box with rounded corners, intended for writing a memo. The box is defined by a thin black border and occupies the majority of the page's vertical space below the "MEMO" header.

---

**MEMO**





# MEMO

A large, empty rectangular box with rounded corners, intended for writing a memo. The box is defined by a thin black border and occupies the majority of the page's vertical space below the "MEMO" header.